



bar **MFE600E**

FEATURES

- The measurement accuracy will not be influenced by the fluid density, viscosity, temperature, pressure and electrical conductivity changes;
- Open flow without moving parts in measuring pipe, no pressure loss;
- Integrated pressure, can measure flow and pressure at the same time;
- No mechanical inertia, with good sensitivity, it can measure the transient pulsating flux, and has good linearity;
- Only the lining and electrodes contact with the media, as long as the selection of electrode and lining materials is proper, they can be corrosion resistance and abrasive resistance, and are able to ensure long-term use;
- Multi-electrode structure ensures high accuracy. With the grounding electrode, it doesn't need grounding ring which saves the cost;
- When power off, EEPROM can protect parameter setting and cumulative values;
- The converter uses a low-power consumption single-chip for processing data which ensure the reliable performance, high accuracy, low power consumption and zero stability. Dot matrix LCD can display the integrated flux, transient flux, velocity, flow percentage and other parameters;
- Two-way measuring system can be used for measuring forward flux and reverse flux; low frequency rectangular wave excitation improves the stability of flow, low power loss and superior low velocity characteristic.



MICROSENSOR

AUTHORIZED DISTRIBUTOR

MFE600E Series Electromagnetic Flowmeter (hereinafter called Electromagnetic Flowmeter) is designed and manufactured with the most advanced domestic and abroad technology, featuring high accuracy, reliability, good stability and long service life.

We pay our attention to every detail in the process of the product structure design, material selection, manufacturing, assembly and factory testing etc. With a water tower up to 37m as pressure stabilizer for actual flow calibration, we have a professional production line for electromagnetic flowmeter, also we design and develop a series of software and hardware for electromagnetic flowmeter for mass production to ensure high quality in long term use. The product has backlight and wide temperature-ranged LCD display. With fully practical function, visual display, easy operation, it saves troubles for on-site installation operation and maintenance. MFE600E can be widely used in industrial fields such as petroleum, chemical, metallurgy, water supply and drainage, steel, coal, paper, food, textile, environmental protection and other municipal administration, water conservancy construction field etc.

WORKING PRINCIPLE

The working principle of Electromagnetic Flowmeter is based on Faraday's Law of Electromagnetic Induction, that is, when the conductive liquid flows through the electromagnetic flowmeter, the induced electromotive force will be produced in the liquid conductor, and the induced electromotive force is directly proportional to the velocity of conductive liquid, magnetic flux density and width of conductor (interior diameter of flowmeter). Such induced electromotive force is detected by a pair of electrodes on the tube wall of the flowmeter, and the equation of induced electromotive force is as follows:

$$U = K \times B \times V \times D$$

U: Induced electromotive force

K: Instrument Constant

B: Magnetic flux density V: Velocity

D: Interior diameter of measuring pipe

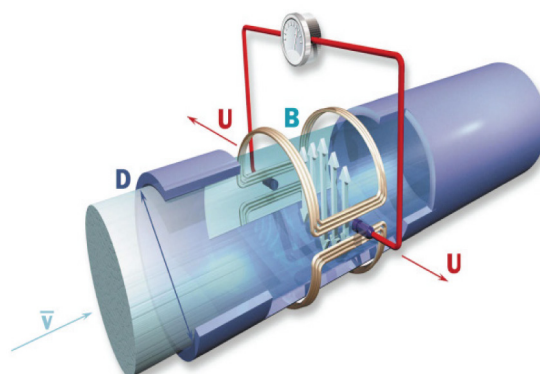

Figure 1 Working principle diagram

SPECIFICATION

Table 1 Specifications

Diameter	Flange type: DN6~DN1600, ≥DN20 with built-in grounding electrode
	Wafer type: DN25~DN200
	Threaded type: DN10~DN50
	Clamp type: DN15~DN150
Explosion-proof	Integrated: Explosion-proof (optional) Ex d ib mb IIC T4 Gb; Separated: non-flameproof
Measurement accuracy	±0.2%(DN10~DN350); ±0.5%(DN6~DN1600)
Pressure port	ANSI 1/2 NPT, JIS G1/2, ISO M20 ×1.5
Electrode type	Standard fixed electrode, antifouling electrode
	DN6~DN20: a pair of measuring electrodes, no grounding electrodes
	DN25~DN500: a pair of measuring electrodes and a pair of grounding electrodes
	≥DN600: 2 pairs of measuring electrodes and a pair of grounding electrodes
Structure type	Integrated type, separated type (cable length of separated type≤100m)
Rated pressure	GB: PN6, PN10, PN16, PN25, PN40, PN63, PN100
	ANSI: CLASS 150, CLASS 300, CLASS 600
	DIN: PN6, PN10, PN16, PN25, PN40, PN63, PN100
	JIS: 10K, 20K, 40K
	Others: customizable
Electrode material	316L, Ti, HB/HC, Ta, WC, Pt
Lining material	Neoprene (CR), Natural Rubber (NR), Polyurethane Rubber (PU)
	Polytetrafluoroethylene (PTFE), F46,PFA
Measured pipe	Stainless steel 06Cr19Ni10(304),304 ASTM,SUS 304
Flange/body flange	Carbon steel (standard), stainless steel (optional) 06Cr19Ni10(304),304 ASTM,SUS 304
Converter housing	No Ground ring DN20 and below,Grounding ring material same as measuring electrode
Ground Ring Form	Aluminum die-casting
Power supply	100V AC~240V AC, 24V DC,12V DC
	3.6V Battery supply (RS485 output, without 4mA~20mA, wireless output, frequency/pulse output, and the frequency/pulse output is used only for calibration or calibration purposes.)
Output signal	4mA~20mA DC (4mA to 0m ³ ; 20mA to full scale) load resistance 0Ω~750Ω, active output
	Hart, Frequency, pulse output (Passive, active output optional)Upper and lower limit alarm output
	RS485 (Modbus protocol), Hart and RS485/RS232 outputs cannot exist at the same time
	Profibus-DP
	4G wireless transmission
Electrical connection	ISO M20×1.5
IP protection	IP65; IP67; IP68
Power consumption	≤5W
Environmental temp.	-20°C ~60°C
Storage temp.	-40°C ~60°C
Relative humidity	5%~90%

05.2024 | version 0001

■ **OUTLINE STRUCTURE**

Integrated flange connection dimensions

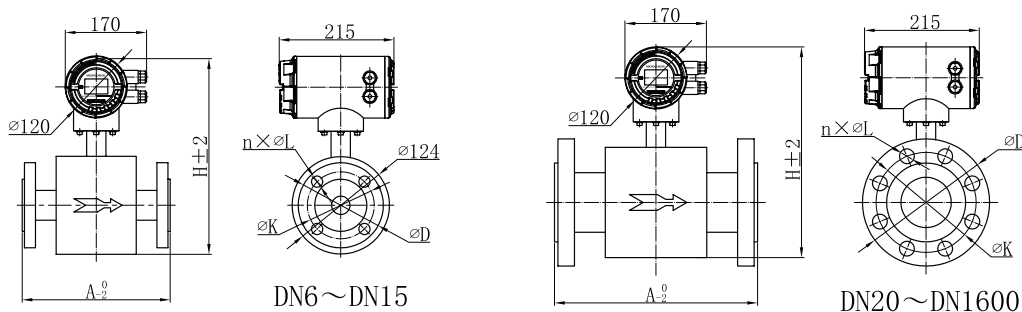

A: duct length of flowmeter; H: flowmeter height; N: bolt holes quantity; L: bolt hole diameter;
K: center circle diameter of bolt hole; D: flange outside diameter.

Integrated flowmeter dimensions

DN	Rated Pressure (MPa)	Outline Dimension(mm)		Flange Connection Dimension(mm)		
		A	H	D	K	n×ΦL
6	0.6 (DIN)	150	304	75	50	4×Φ11
10		150	304	75	50	4×Φ11
15		150	304	80	55	4×Φ11
20		150	304	90	65	4×Φ11
25		150	312	100	75	4×Φ11
32		150	330	120	90	4×Φ14
40		150	340	130	100	4×Φ14
50		200	338	140	110	4×Φ14
65		200	358	160	130	4×Φ14
80		200	374	190	150	4×Φ18
100		250	402	210	170	4×Φ18
125		250	425	240	200	8×Φ18
150		300	458	265	225	8×Φ18
200		350	522	320	280	8×Φ18
250		400	574	375	335	12×Φ18
300		500	624	440	395	12×Φ23
350		500	678	490	445	12×Φ23
400		600	742	540	495	16×Φ23
450		600	794	595	550	20×Φ23
500		600	862	645	600	20×Φ23
600	600	950	755	705	20×Φ25	
700	700	1058	860	810	24×Φ25	
800	800	1166	975	920	24×Φ30	
900	900	1272	1075	1020	28×Φ30	
1000	1000	1376	1175	1120	28×Φ30	
1200	1200	1578	1405	1340	32×Φ32	
1400	1400	1840	1630	1560	36×Φ36	
1600	1600	2078	1830	1760	40×Φ36	

Integrated flange connection dimensions

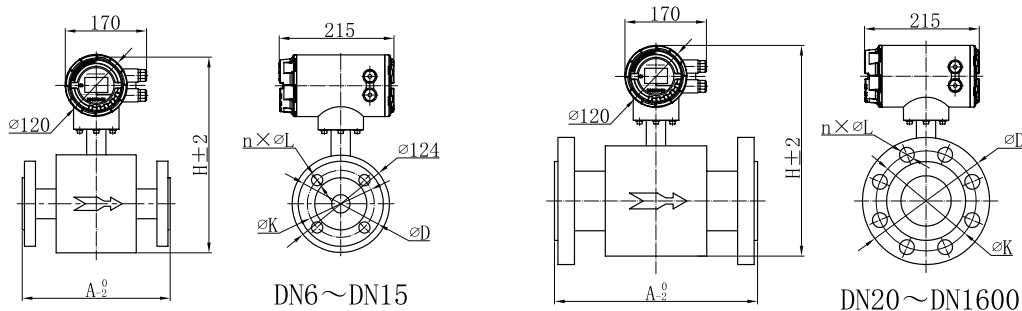

A: duct length of flowmeter; H: flowmeter height; N: bolt holes quantity; L: bolt hole diameter;
K: center circle diameter of bolt hole; D: flange outside diameter.

Integrated flowmeter dimensions

DN	Rated Pressure (MPa)	Outline Dimension(mm)		Flange Connection Dimension(mm)		
		A	H	D	K	n×ΦL
6	1.0 (DIN)	150	304	90	60	4×Φ14
10		150	304	90	60	4×Φ14
15		150	304	95	65	4×Φ14
20		150	304	105	75	4×Φ14
25		150	312	115	85	4×Φ14
32		150	330	140	100	4×Φ18
40		150	340	150	110	4×Φ18
50		200	338	165	125	4×Φ18
65		200	358	185	145	8×Φ18
80		200	374	200	160	8×Φ18
100		250	402	220	180	8×Φ18
125		250	425	250	210	8×Φ18
150		300	458	285	240	8×Φ23
200		350	522	340	270	8×Φ23
250		400	574	395	350	12×Φ23
300		500	624	445	400	12×Φ23
350		500	678	505	460	16×Φ23
400		600	742	565	515	16×Φ25
450		600	794	615	565	20×Φ25
500		600	862	670	620	20×Φ25
600		600	950	780	725	20×Φ25
700		700	1058	895	840	24×Φ30
800		800	1166	1015	950	24×Φ34
900		900	1272	1115	1050	28×Φ34
1000		1000	1376	1230	1150	28×Φ36
1200		1200	1578	1455	1380	32×Φ39
1400		1400	1840	1675	1590	36×Φ42
1600		1600	2078	1915	1820	40×Φ48

05.2024 | version 0001

Integrated flange connection dimensions

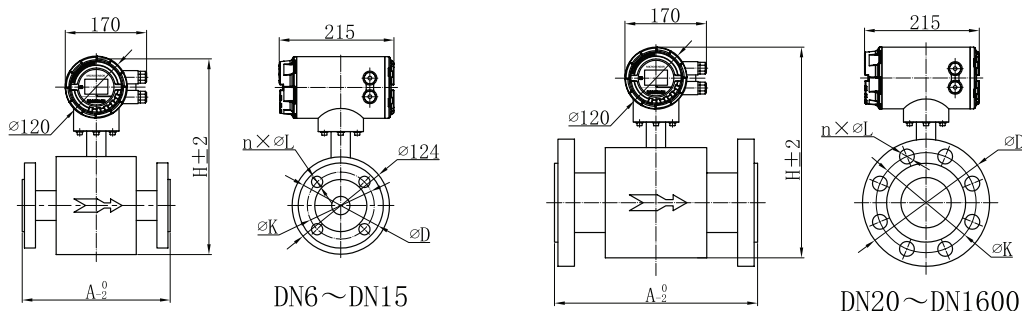

A: duct length of flowmeter; H: flowmeter height; N: bolt holes quantity; L: bolt hole diameter;
K: center circle diameter of bolt hole; D: flange outside diameter.

Integrated flowmeter dimensions

DN	Rated Pressure (MPa)	Outline Dimension(mm)		Flange Connection Dimension(mm)		
		A	H	D	K	n×ΦL
6	1.6 (DIN)	150	304	90	60	4×Φ14
10		150	304	90	60	4×Φ14
15		150	304	95	65	4×Φ14
20		150	304	105	75	4×Φ14
25		150	312	115	85	4×Φ14
32		150	330	140	100	4×Φ18
40		150	340	150	110	4×Φ18
50		200	338	165	125	4×Φ18
65		200	358	185	145	8×Φ18
80		200	374	200	160	8×Φ18
100		250	402	220	180	8×Φ18
125		250	425	250	210	8×Φ18
150		300	458	285	240	8×Φ23
200		350	522	340	295	12×Φ23
250		400	574	395	350	12×Φ25
300		500	624	445	400	12×Φ25
350		500	678	500	460	16×Φ25
400		600	742	565	515	16×Φ30
450		600	794	615	565	20×Φ30
500		600	862	670	620	20×Φ33
600		600	950	780	725	20×Φ36
700		700	1058	895	840	24×Φ36
800		800	1166	1010	950	24×Φ39
900		900	1272	1110	1050	28×Φ39
1000		1000	1376	1220	1160	28×Φ42
1200		1200	1578	1405	1340	32×Φ48
1400		1400	1840	1630	1560	36×Φ48
1600		1600	2078	1830	1760	40×Φ56

05.2024 | version 0001

Integrated flange connection dimensions

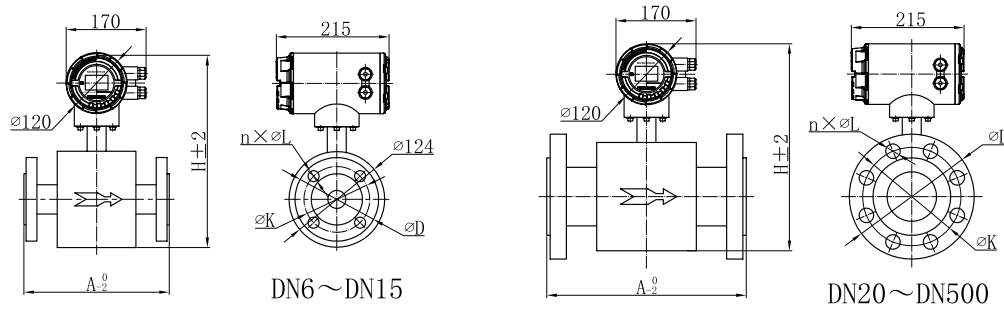

A: duct length of flowmeter; H: flowmeter height; N: bolt holes quantity; L: bolt hole diameter;
K: center circle diameter of bolt hole; D: flange outside diameter.

Integrated flowmeter dimensions

DN	Rated Pressure (MPa)	Outline Dimension(mm)		Flange Connection Dimension(mm)		
		A	H	D	K	n×ΦL
6	2.5 (DIN)	150	304	90	60	4×Φ14
10		150	304	90	60	4×Φ14
15		150	304	95	65	4×Φ14
20		150	304	105	75	4×Φ14
25		150	312	115	85	4×Φ14
32		150	330	140	100	4×Φ18
40		150	340	150	110	4×Φ18
50		200	338	165	125	4×Φ18
65		200	358	185	145	8×Φ18
80		200	374	200	160	8×Φ18
100		250	402	235	180	8×Φ22
125		250	425	270	220	8×Φ26
150		300	458	300	250	8×Φ26
200		350	522	360	310	12×Φ26
250		400	574	425	370	12×Φ25
300		500	624	485	430	12×Φ30
350		500	678	555	490	16×Φ33
400		600	742	620	550	16×Φ36
450		600	794	670	600	20×Φ36
500		600	862	730	660	20×Φ36

05.2024 | version 0001

Integrated flange connection dimensions

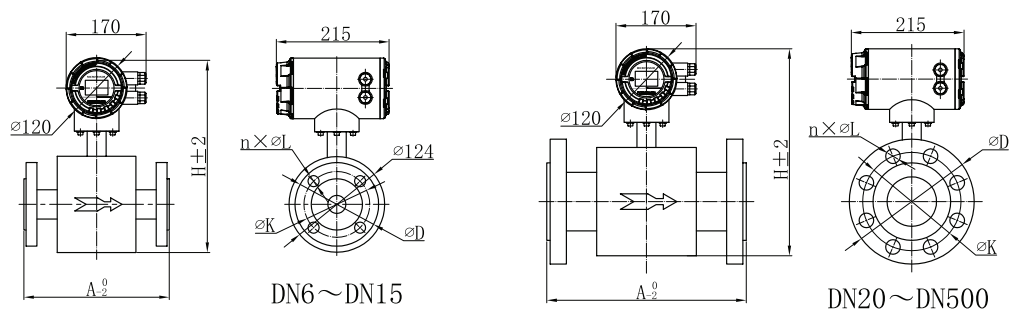

A: duct length of flowmeter; H: flowmeter height; N: bolt holes quantity; L: bolt hole diameter;
K: center circle diameter of bolt hole; D: flange outside diameter.

Integrated flowmeter dimensions

DN	Rated Pressure (MPa)	Outline Dimension(mm)		Flange Connection Dimension(mm)		
		A	H	D	K	n×ΦL
6	4.0 (DIN)	150	304	90	60	4×Φ14
10		150	304	90	60	4×Φ14
15		150	304	95	65	4×Φ14
20		150	304	105	75	4×Φ14
25		150	312	115	85	4×Φ14
32		150	330	140	100	4×Φ18
40		150	340	150	110	4×Φ18
50		200	338	165	125	4×Φ18
65		200	358	185	145	8×Φ18
80		200	374	200	160	8×Φ18
100		250	402	235	180	8×Φ22
125		250	425	270	220	8×Φ26
150		300	458	300	250	8×Φ26
200		350	522	360	310	12×Φ26
250		400	574	425	370	12×Φ25
300		500	624	485	430	12×Φ30
350		500	678	555	490	16×Φ33
400		600	742	620	550	16×Φ36
450		600	794	670	600	20×Φ36
500		600	862	730	660	20×Φ36

05.2024 | version 0001

Integrated flange connection dimensions

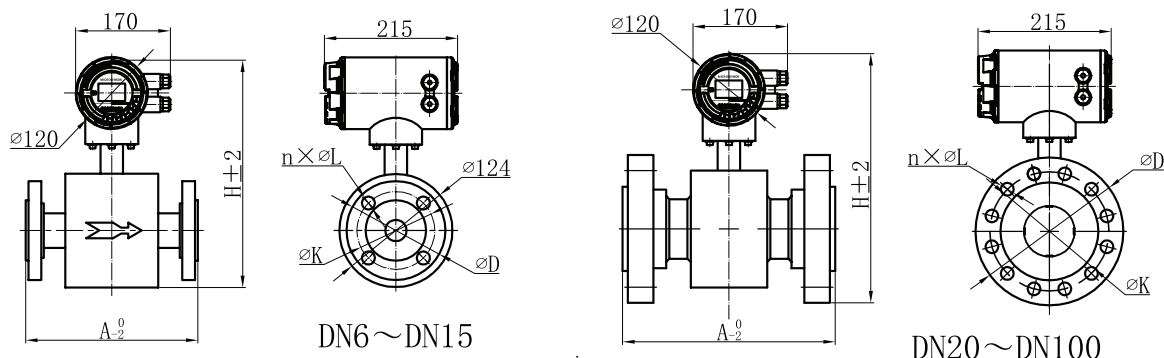

A: duct length of flowmeter; H: flowmeter height; N: bolt holes quantity; L: bolt hole diameter;
K: center circle diameter of bolt hole; D: flange outside diameter.

Integrated flowmeter dimensions

DN	Rated Pressure (MPa)	Outline Dimension(mm)		Flange Connection Dimension(mm)		
		A	H	D	K	n×ΦL
6	6.3 (DIN)	150	304	90	60	4×Φ14
10		150	304	100	70	4×Φ14
15		150	304	105	75	4×Φ14
20		150	304	130	90	4×Φ18
25		150	312	140	100	4×Φ18
32		150	330	155	110	4×Φ22
40		150	340	170	125	4×Φ22
50		200	338	180	135	4×Φ22
65		200	358	205	160	8×Φ22
80		200	374	215	170	8×Φ22
100		250	402	250	200	8×Φ26

Integrated flange connection dimensions

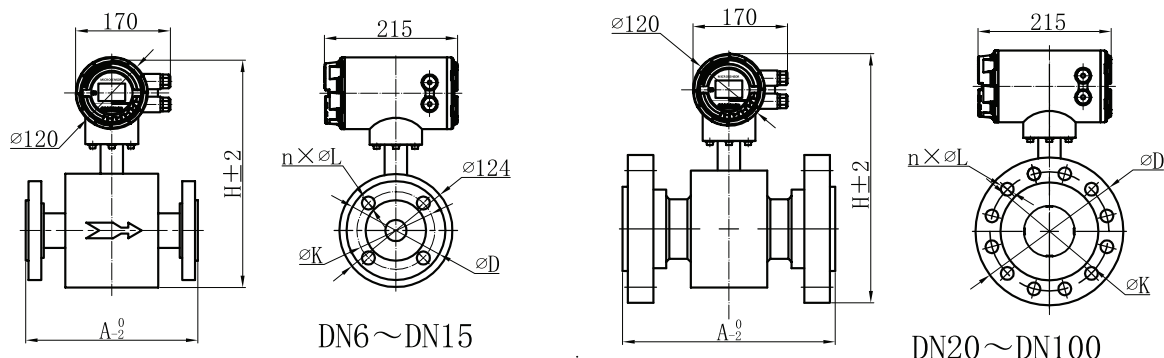

A: duct length of flowmeter; H: flowmeter height; N: bolt holes quantity; L: bolt hole diameter;
K: center circle diameter of bolt hole; D: flange outside diameter.

Integrated flowmeter dimensions

DN	Rated Pressure (MPa)	Outline Dimension(mm)		Flange Connection Dimension(mm)		
		A	H	D	K	n×ΦL
6	10 (DIN)	150	304	90	60	4×Φ14
10		150	304	100	70	4×Φ14
15		150	304	105	75	4×Φ14
20		150	304	130	90	4×Φ18
25		150	312	140	100	4×Φ18
32		150	330	155	110	4×Φ22
40		150	340	170	125	4×Φ22
50		200	338	195	135	4×Φ26
65		200	358	220	160	8×Φ26
80		200	374	230	170	8×Φ26
100		250	402	265	210	8×Φ30

Integrated flange connection dimensions

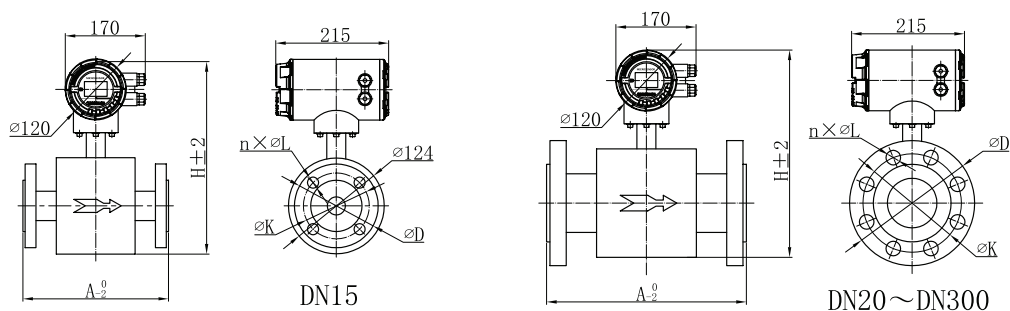

A: duct length of flowmeter; H: flowmeter height; N: bolt holes quantity; L: bolt hole diameter;
K: center circle diameter of bolt hole; D: flange outside diameter.

Integrated flowmeter dimensions

DN	Rated Pressure (MPa)	Outline Dimension(mm)		Flange Connection Dimension(mm)		
		A	H	D	K	n×ΦL
15	ANSI 150LB	150	302	90	60.5	4×16
20		150	302	100	70	4×16
25		150	306	110	79.5	4×16
32		150	316	120	89	4×16
40		150	325	130	98.5	4×16
50		200	330	150	120.5	4×18
65		200	354	180	139.5	4×18
80		200	366	190	152.5	4×18
100		250	404	230	190.5	8×18
125		250	426	255	216	8×22
150		300	454	280	241.5	8×22
200		350	524	345	298.5	8×22
250		400	580	405	362	12×26
300		500	645	485	432	12×26

Integrated flange connection dimensions

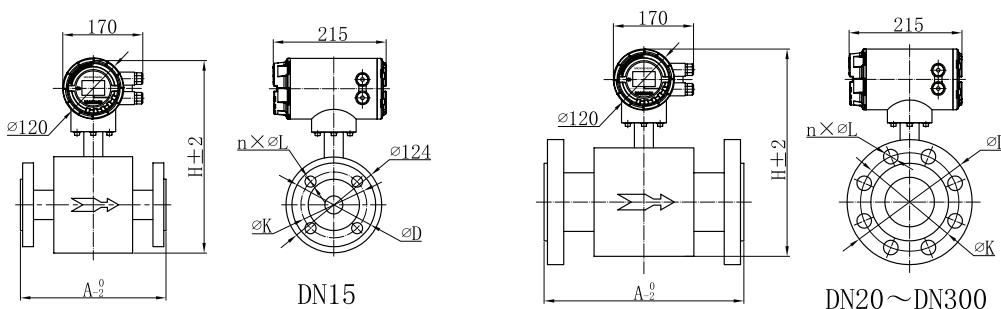

A: duct length of flowmeter; H: flowmeter height; N: bolt holes quantity; L: bolt hole diameter;
K: center circle diameter of bolt hole; D: flange outside diameter.

Integrated flowmeter dimensions

DN	Rated Pressure (MPa)	Outline Dimension(mm)		Flange Connection Dimension(mm)		
		A	H	D	K	n×φL
15	ANSI 300LB	150	304	95	66.7	4×16
20		150	304	115	82.6	4×18
25		150	312	125	88.9	4×18
32		150	330	135	98.4	4×18
40		150	340	155	114.3	4×22
50		200	338	165	127	8×18
65		250	358	190	149.2	8×22
80		250	374	210	168.3	8×22
100		250	402	255	200	8×22
125		250	425	280	235	8×22
150		300	458	320	269.9	12×22
200		350	522	380	330.2	12×26
250		450	574	445	387.4	16×30
300		500	624	520	450.8	16×32

Integrated flange connection dimensions

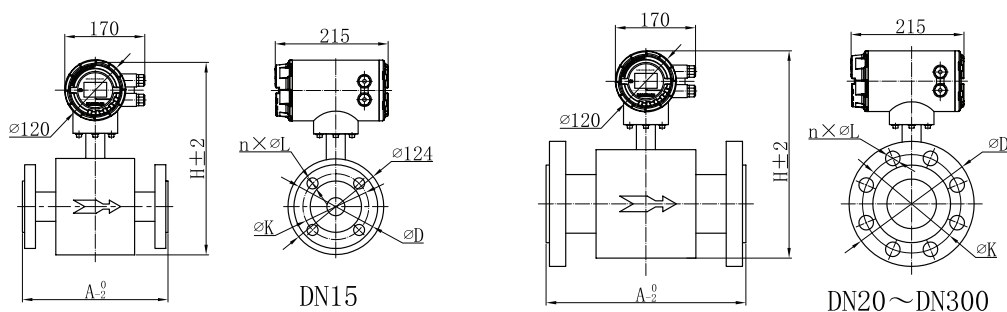

A: duct length of flowmeter; H: flowmeter height; N: bolt holes quantity; L: bolt hole diameter;
K: center circle diameter of bolt hole; D: flange outside diameter.

Integrated flowmeter dimensions

DN	Rated Pressure (MPa)	Outline Dimension(mm)		Flange Connection Dimension(mm)		
		A	H	D	K	n×ØL
15	ANSI 600LB	200	304	95	66.7	4×16
20		200	304	115	82.6	4×18
25		200	312	125	88.9	4×18
32		200	330	135	98.4	4×18
40		250	340	155	114.3	4×22
50		250	338	165	127	8×18
65		300	358	190	149.2	8×22
80		300	374	210	168.3	8×22
100		300	402	275	215.9	8×26
125		300	425	330	266.7	8×30
150		350	458	355	292.1	12×30
200		400	522	420	349.2	12×33
250		500	574	510	431.8	16×36
300		500	624	560	489	20×36

Integrated flange connection dimensions

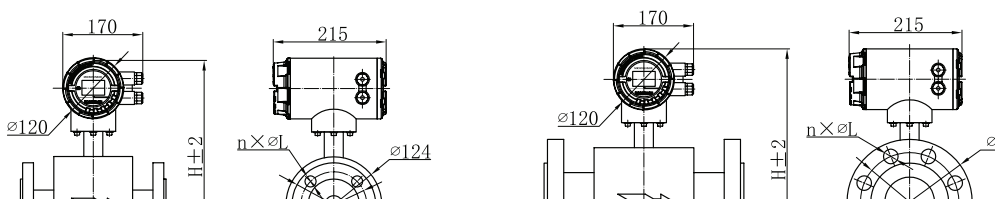

A: duct length of flowmeter; H: flowmeter height; N: bolt holes quantity; L: bolt hole diameter;
K: center circle diameter of bolt hole; D: flange outside diameter.

Integrated flowmeter dimensions

DN	Rated Pressure (MPa)	Outline Dimension(mm)		Flange Connection Dimension(mm)		
		A	H	D	K	n×ΦL
15	10K (JIS)	150	304	95	66.5	4×12
20		150	304	100	82.5	4×12
25		150	307	125	89	4×12
32		150	328	135	98	4×16
40		150	335	140	114	4×16
50		200	333	155	127	4×16
65		200	353	175	149	4×16
80		200	367	185	168	8×16
100		250	397	210	216	8×16
125		250	425	250	267	8×20
150		300	455	280	292	8×20
200		350	517	330	349	12×20
250		400	572	400	432	12×22
300		500	624	445	489	16×22

Integrated flange connection dimensions

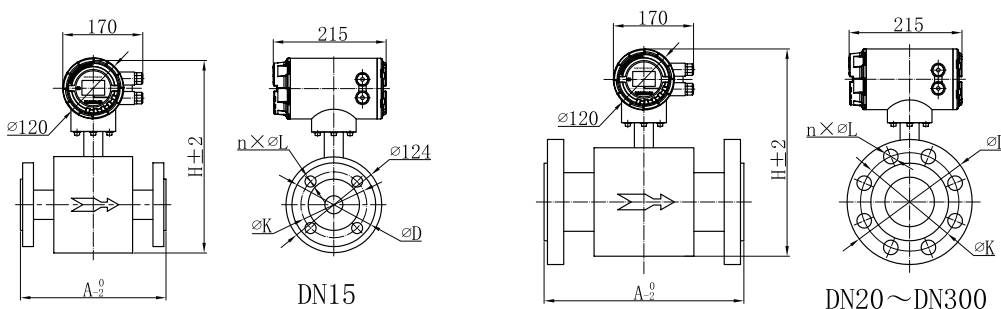

A: duct length of flowmeter; H: flowmeter height; N: bolt holes quantity; L: bolt hole diameter;
K: center circle diameter of bolt hole; D: flange outside diameter.

Integrated flowmeter dimensions

DN	Rated Pressure (MPa)	Outline Dimension(mm)		Flange Connection Dimension(mm)		
		A	H	D	K	n×øL
15	20K (JIS)	150	304	95	70	4×15
20		150	304	100	75	4×15
25		150	312	125	90	4×19
32		150	330	135	100	4×19
40		150	340	140	105	8×19
50		200	338	155	120	8×19
65		250	358	175	140	8×19
80		250	374	200	160	8×23
100		250	402	225	185	8×23
125		250	425	270	225	8×25
150		300	458	305	260	12×25
200		350	522	350	305	12×25
250		450	574	430	380	12×27
300		500	624	480	430	16×27

Integrated flange connection dimensions

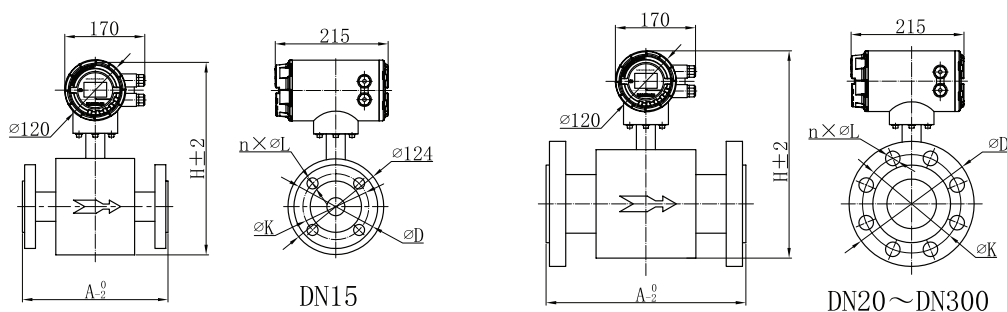

A: duct length of flowmeter; H: flowmeter height; N: bolt holes quantity; L: bolt hole diameter;
K: center circle diameter of bolt hole; D: flange outside diameter.

Integrated flowmeter dimensions

DN	Rated Pressure (MPa)	Outline Dimension(mm)		Flange Connection Dimension(mm)		
		A	H	D	K	n×φL
15	40K (JIS)	200	304	115	80	4×19
20		200	304	120	85	4×19
25		200	312	130	95	4×19
32		200	330	140	105	4×19
40		250	340	160	120	4×23
50		250	338	165	130	8×19
65		300	358	200	160	8×23
80		300	374	210	170	8×23
100		300	402	250	205	8×23
125		300	425	300	250	8×27
150		350	458	355	295	12×33
200		400	522	405	345	12×33
250		500	574	475	410	12×33
300		500	624	540	470	16×39

Separated flange connection dimensions

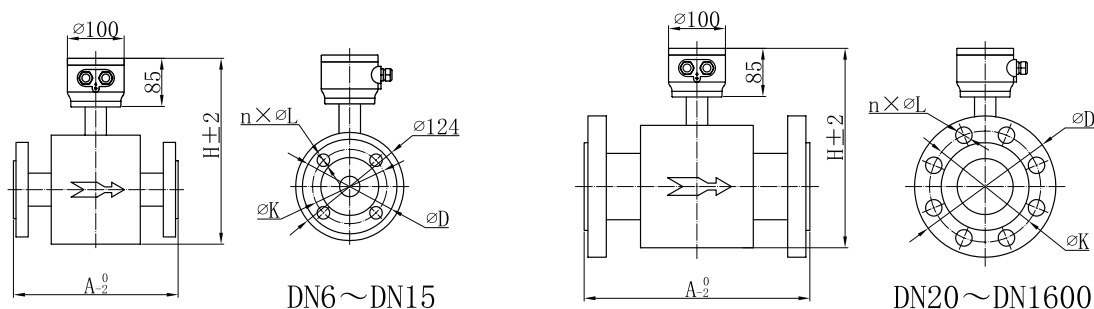

A: duct length of flowmeter; H: flowmeter height; N: bolt holes quantity; L: bolt hole diameter;
K: center circle diameter of bolt hole; D: flange outside diameter.

Separated flowmeter dimensions

DN	Rated Pressure (MPa)	Outline Dimension(mm)		Flange Connection Dimension(mm)		
		A	H	D	K	n×ΦL
6	0.6 (DIN)	150	245	75	50	4×Φ11
10		150	245	75	50	4×Φ11
15		150	245	80	55	4×Φ11
20		150	245	90	65	4×Φ11
25		150	252	100	75	4×Φ11
32		150	270	120	90	4×Φ14
40		150	280	130	100	4×Φ14
50		200	280	140	110	4×Φ14
65		200	300	160	130	4×Φ14
80		200	314	190	150	4×Φ18
100		250	342	210	170	4×Φ18
125		250	366	240	200	8×Φ18
150		300	400	265	225	8×Φ18
200		350	464	320	280	8×Φ18
250		400	516	375	335	12×Φ18
300		500	566	440	395	12×Φ23
350		500	618	490	445	12×Φ23
400		600	682	540	495	16×Φ23
450		600	734	595	550	20×Φ23
500		600	802	645	600	20×Φ23
600		600	892	755	705	20×Φ25
700		700	998	860	810	24×Φ25
800		800	1106	975	920	24×Φ30
900		900	1212	1075	1020	28×Φ30
1000		1000	1316	1175	1120	28×Φ30
1200		1200	1518	1405	1340	32×Φ32
1400		1400	1780	1630	1560	36×Φ36
1600		1600	2018	2180	1830	40×Φ36

Separated flange connection dimensions

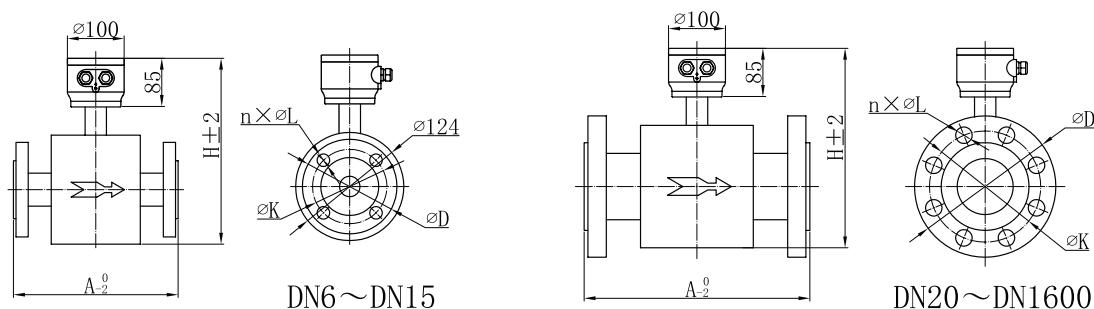

A: duct length of flowmeter; H: flowmeter height; N: bolt holes quantity; L: bolt hole diameter;
K: center circle diameter of bolt hole; D: flange outside diameter.

Separated flowmeter dimensions

DN	Rated Pressure (MPa)	Outline Dimension(mm)		Flange Connection Dimension(mm)		
		A	H	D	K	n×ΦL
6	1.0 (DIN)	150	245	90	60	4×Φ14
10		150	245	90	60	4×Φ14
15		150	245	95	65	4×Φ14
20		150	245	105	75	4×Φ14
25		150	252	115	85	4×Φ14
32		150	270	140	100	4×Φ18
40		150	280	150	110	4×Φ18
50		200	280	165	125	4×Φ18
65		200	300	185	145	8×Φ18
80		200	314	200	160	8×Φ18
100		250	342	220	180	8×Φ18
125		250	366	250	210	8×Φ18
150		300	400	285	240	8×Φ23
200		350	464	340	270	8×Φ23
250		400	516	395	350	12×Φ23
300		500	566	445	400	12×Φ23
350		500	618	505	460	16×Φ23
400		600	682	565	515	16×Φ25
450		600	734	615	565	20×Φ25
500		600	802	670	620	20×Φ25
600		600	892	780	725	20×Φ25
700		700	998	895	840	24×Φ30
800		800	1106	1015	950	24×Φ34
900		900	1212	1115	1050	28×Φ34
1000		1000	1316	1230	1150	28×Φ36
1200		1200	1518	1455	1380	32×Φ39
1400		1400	1780	1675	1590	36×Φ42
1600		1600	2018	1915	1820	40×Φ48

05.2024 | version 0001

Separated flange connection dimensions

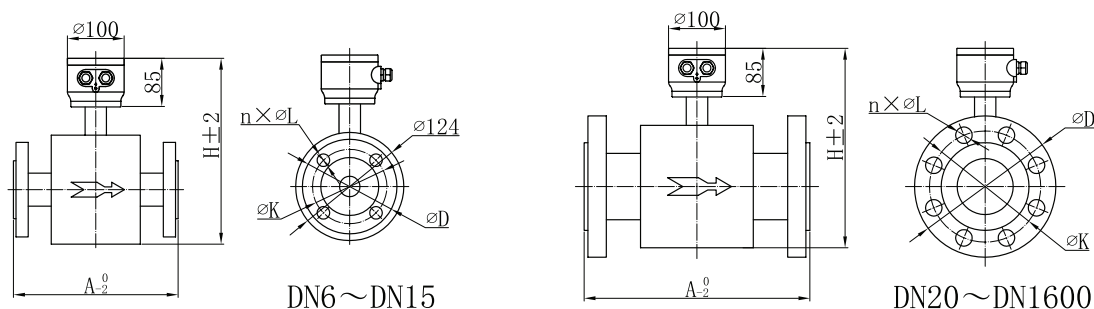

A: duct length of flowmeter; H: flowmeter height; N: bolt holes quantity; L: bolt hole diameter;
K: center circle diameter of bolt hole; D: flange outside diameter.

Separated flowmeter dimensions

DN	Rated Pressure (MPa)	Outline Dimension(mm)		Flange Connection Dimension(mm)		
		A	H	D	K	n×ΦL
6	1.6 (DIN)	150	245	90	60	4×Φ14
10		150	245	Φ90	60	4×Φ14
15		150	245	Φ95	65	4×Φ14
20		150	245	105	75	4×Φ14
25		150	252	115	85	4×Φ14
32		150	270	140	100	4×Φ18
40		150	280	150	110	4×Φ18
50		200	280	165	125	4×Φ18
65		200	300	185	145	8×Φ18
80		200	314	200	160	8×Φ18
100		250	342	220	180	8×Φ18
125		250	366	250	210	8×Φ18
150		300	400	285	240	8×Φ23
200		350	464	340	295	12×Φ23
250		400	516	395	350	12×Φ25
300		500	566	445	400	12×Φ25
350		500	618	500	460	16×Φ25
400		600	682	656	515	16×Φ30
450		600	734	615	565	20×Φ30
500		600	802	670	620	20×Φ33
600		600	892	780	725	20×Φ36
700		700	998	895	840	24×Φ36
800		800	1106	1010	950	24×Φ39
900		900	1212	1110	1050	28×Φ39
1000		1000	1316	1220	1160	28×Φ42
1200		1200	1518	1405	1340	32×Φ48
1400		1400	1780	1630	1560	36×Φ48
1600		1600	2018	2180	1830	40×Φ56

Separated flange connection dimensions

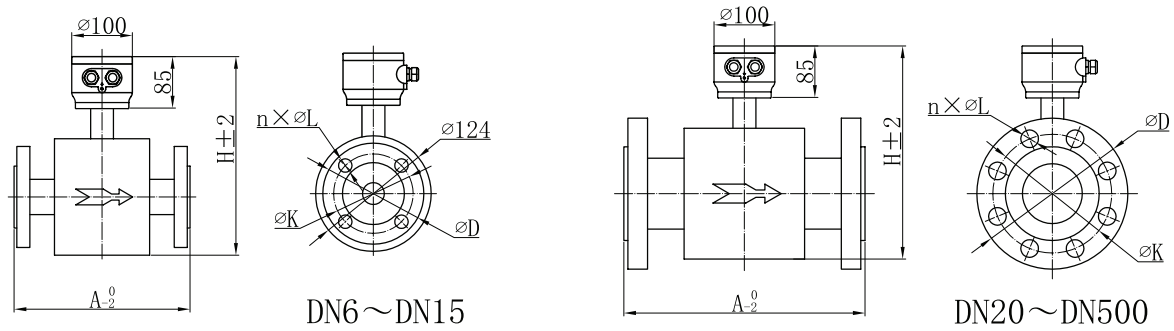

A: duct length of flowmeter; H: flowmeter height; N: bolt holes quantity; L: bolt hole diameter;
K: center circle diameter of bolt hole; D: flange outside diameter.

Separated flowmeter dimensions

DN	Rated Pressure (MPa)	Outline Dimension(mm)		Flange Connection Dimension(mm)		
		A	H	D	K	n×ΦL
6	2.5 (DIN)	150	245	90	60	4×Φ14
10		150	245	90	60	4×Φ14
15		150	245	95	65	4×Φ14
20		150	245	105	75	4×Φ14
25		150	252	115	85	4×Φ14
32		150	270	140	100	4×Φ18
40		150	280	150	110	4×Φ18
50		200	280	165	125	4×Φ18
65		200	300	185	145	8×Φ18
80		200	314	200	160	8×Φ18
100		250	342	235	180	8×Φ22
125		250	366	270	220	8×Φ26
150		300	400	300	250	8×Φ26
200		350	464	360	310	12×Φ26
250		400	516	425	370	12×Φ25
300		500	566	485	430	12×Φ30
350		500	618	555	490	16×Φ33
400		600	682	620	550	16×Φ36
450		600	734	670	600	20×Φ36
500		600	802	730	660	20×Φ36

05.2024 | version 0001

Separated flange connection dimensions

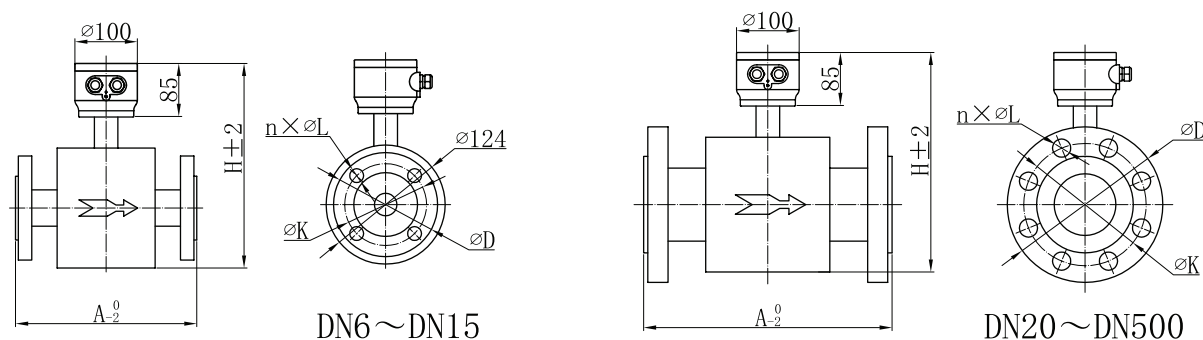

A: duct length of flowmeter; H: flowmeter height; N: bolt holes quantity; L: bolt hole diameter;
K: center circle diameter of bolt hole; D: flange outside diameter.

Separated flowmeter dimensions

DN	Rated Pressure (MPa)	Outline Dimension(mm)		Flange Connection Dimension(mm)		
		A	H	D	K	n×ΦL
6	4.0 (DIN)	150	245	90	60	4×Φ14
10		150	245	90	60	4×Φ14
15		150	245	95	65	4×Φ14
20		150	245	105	75	4×Φ14
25		150	252	115	85	4×Φ14
32		150	270	140	100	4×Φ18
40		150	280	150	110	4×Φ18
50		200	280	165	125	4×Φ18
65		200	300	185	145	8×Φ18
80		200	314	200	160	8×Φ18
100		250	342	235	190	8×Φ22
125		250	366	270	220	8×Φ26
150		300	400	300	250	8×Φ26
200		350	464	375	320	12×Φ23
250		400	516	450	385	12×Φ30
300		500	566	515	450	16×Φ33
350		500	618	580	510	16×Φ36
400		600	682	660	585	16×Φ39
450		600	734	685	610	20×Φ39
500		600	802	755	670	20×Φ42

05.2024 | version 0001

Separated flange connection dimensions

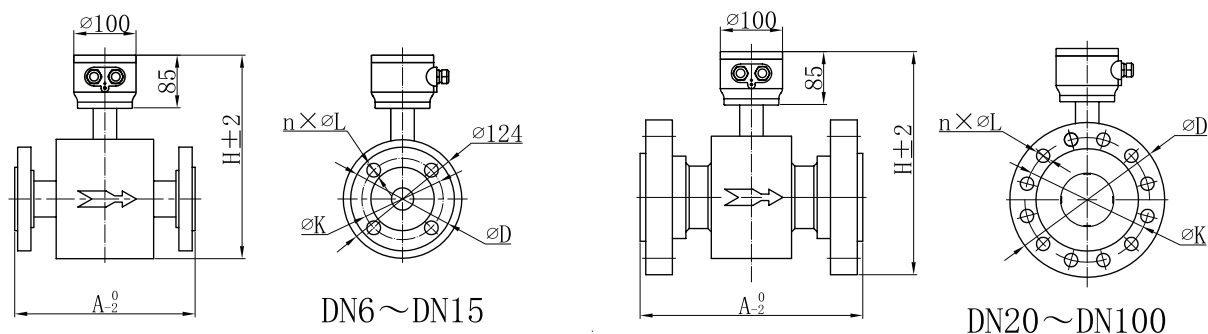

A: duct length of flowmeter; H: flowmeter height; N: bolt holes quantity; L: bolt hole diameter;
K: center circle diameter of bolt hole; D: flange outside diameter.

Separated flowmeter dimensions

DN	Rated Pressure (MPa)	Outline Dimension(mm)		Flange Connection Dimension(mm)		
		A	H	D	K	n×ØL
6	6.3 (DIN)	150	245	90	60	4×Ø14
10		150	245	100	70	4×Ø14
15		150	245	105	75	4×Ø14
20		150	245	130	90	4×Ø18
25		150	252	140	100	4×Ø18
32		150	270	155	110	4×Ø22
40		150	280	170	125	4×Ø22
50		200	280	180	135	4×Ø22
65		200	300	205	160	8×Ø22
80		200	314	215	170	8×Ø22
100		250	342	250	200	8×Ø26

Separated flange connection dimensions

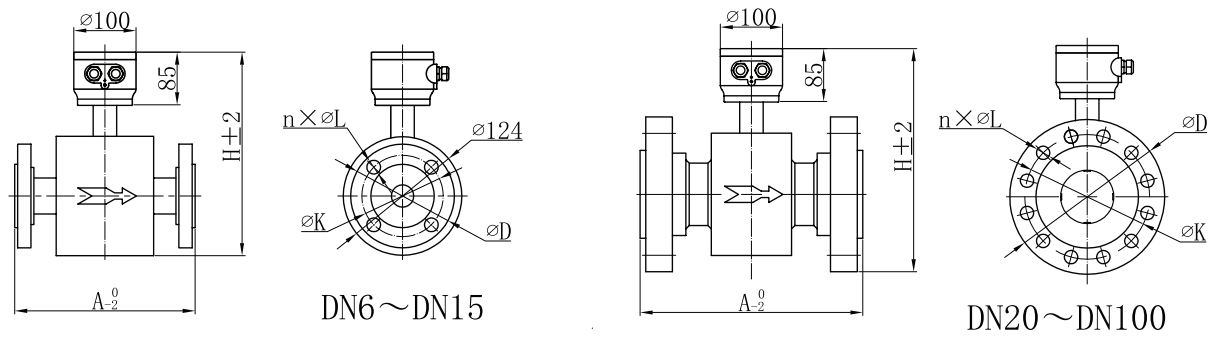

A: duct length of flowmeter; H: flowmeter height; N: bolt holes quantity; L: bolt hole diameter;
K: center circle diameter of bolt hole; D: flange outside diameter.

Separated flowmeter dimensions

DN	Rated Pressure (MPa)	Outline Dimension(mm)		Flange Connection Dimension(mm)		
		A	H	D	K	n×ΦL
6	10 (DIN)	150	245	90	60	4×Φ14
10		150	245	100	70	4×Φ14
15		150	245	105	75	4×Φ14
20		150	245	130	90	4×Φ18
25		150	252	140	100	4×Φ18
32		150	270	155	110	4×Φ22
40		150	280	170	125	4×Φ22
50		200	280	195	135	4×Φ26
65		200	300	220	160	8×Φ26
80		200	314	230	170	8×Φ26
100		250	342	265	210	8×Φ30

Separated flange connection dimensions

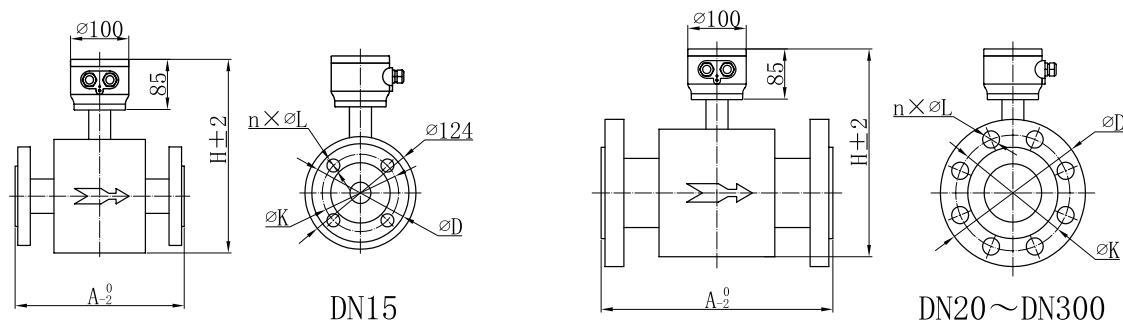

A: duct length of flowmeter; H: flowmeter height; N: bolt holes quantity; L: bolt hole diameter;
K: center circle diameter of bolt hole; D: flange outside diameter.

Separated flowmeter dimensions

DN	Rated Pressure (MPa)	Outline Dimension(mm)		Flange Connection Dimension(mm)		
		A	H	D	K	n×ΦL
15	ANSI 150LB	150	242	90	60.5	4×16
20		150	242	100	70	4×16
25		150	250	110	79.5	4×16
32		150	260	120	89	4×16
40		150	260	130	98.5	4×16
50		200	272	150	120.5	4×18
65		200	298	180	139.5	4×18
80		200	309	190	152.5	4×18
100		250	337	230	190.5	8×18
125		250	364	255	216	8×22
150		300	398	280	241.5	8×22
200		350	465	345	298.5	8×22
250		400	510	405	362	12×26
300		500	546	485	432	12×26

Separated flange connection dimensions

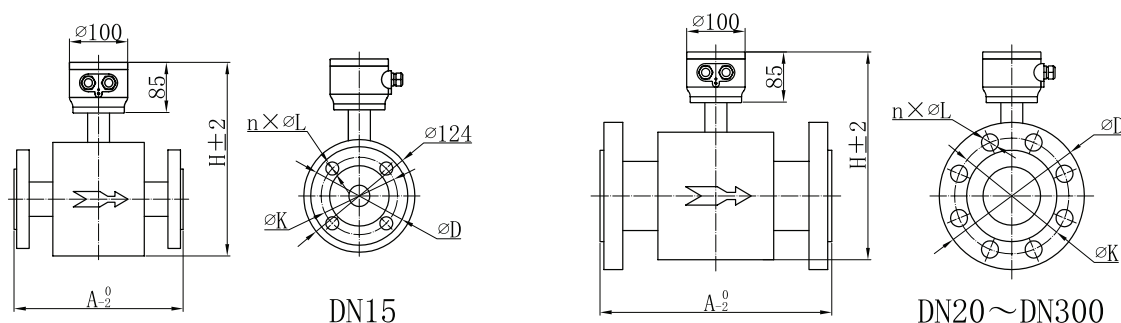

A: duct length of flowmeter; H: flowmeter height; N: bolt holes quantity; L: bolt hole diameter;
K: center circle diameter of bolt hole; D: flange outside diameter.

Separated flowmeter dimensions

DN	Rated Pressure (MPa)	Outline Dimension(mm)		Flange Connection Dimension(mm)		
		A	H	D	K	n×ΦL
15	ANSI 300LB	150	245	95	66.7	4×16
20		150	245	115	82.6	4×18
25		150	252	125	88.9	4×18
32		150	270	135	98.4	4×18
40		150	280	155	114.3	4×22
50		200	280	165	127	8×18
65		250	300	190	149.2	8×22
80		250	314	210	168.3	8×22
100		250	342	255	200	8×22
125		250	366	280	235	8×22
150		300	400	320	269.9	12×22
200		350	464	380	330.2	12×26
250		450	516	445	387.4	16×30
300		500	566	520	450.8	16×32

Separated flange connection dimensions

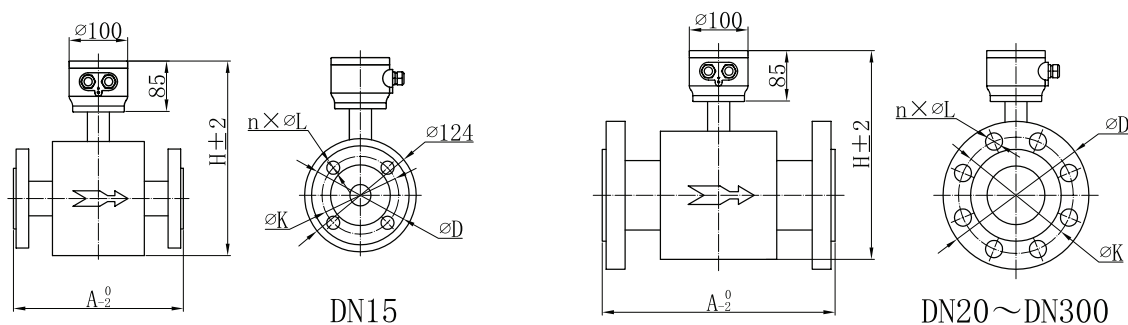

A: duct length of flowmeter; H: flowmeter height; N: bolt holes quantity; L: bolt hole diameter;
K: center circle diameter of bolt hole; D: flange outside diameter.

Separated flowmeter dimensions

DN	Rated Pressure (MPa)	Outline Dimension(mm)		Flange Connection Dimension(mm)		
		A	H	D	K	n×ΦL
15	ANSI 600LB	200	245	95	66.7	4×16
20		200	245	115	82.6	4×18
25		200	247	125	88.9	4×18
32		200	267	135	98.4	4×18
40		250	275	155	114.3	4×22
50		250	270	165	127	8×18
65		300	295	190	149.2	8×22
80		300	307	210	168.3	8×22
100		300	337	275	215.9	8×26
125		300	366	330	266.7	8×30
150		350	398	355	292.1	12×30
200		400	460	420	349.2	12×33
250		500	514	510	431.8	16×36
300		500	566	560	489	20×36

Separated flange connection dimensions

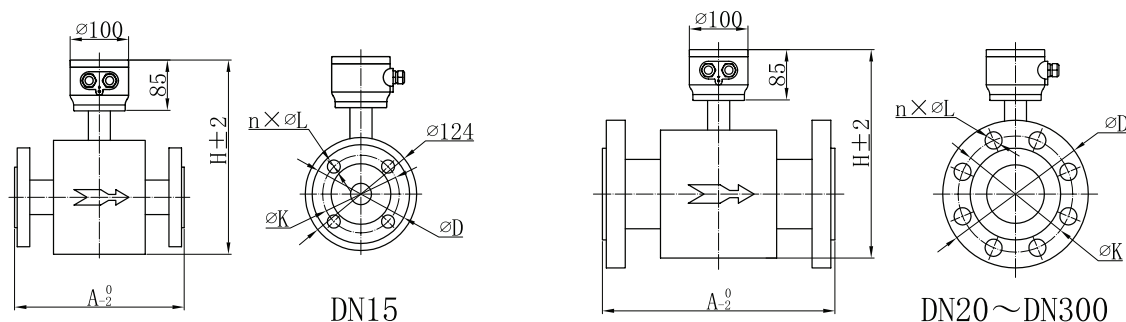

A: duct length of flowmeter; H: flowmeter height; N: bolt holes quantity; L: bolt hole diameter;
K: center circle diameter of bolt hole; D: flange outside diameter.

Separated flowmeter dimensions

DN	Rated Pressure (MPa)	Outline Dimension(mm)		Flange Connection Dimension(mm)		
		A	H	D	K	n×ΦL
15	10K (JIS)	150	245	95	66.5	4×12
20		150	245	100	82.5	4×12
25		150	247	125	89	4×12
32		150	267	135	98	4×16
40		150	275	140	114	4×16
50		200	270	155	127	4×16
65		200	295	175	149	4×16
80		200	307	185	168	8×16
100		250	337	210	216	8×16
125		250	366	250	267	8×20
150		300	398	280	292	8×20
200		350	460	330	349	12×20
250		400	514	400	432	12×22
300		500	566	445	489	16×22

Separated flange connection dimensions

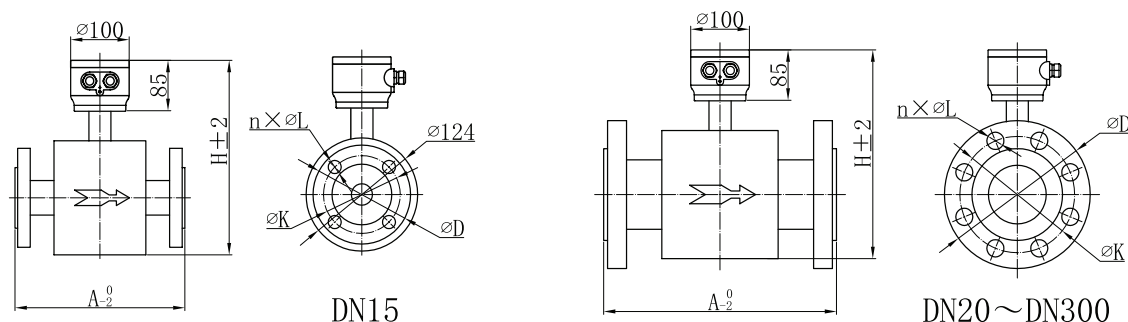

A: duct length of flowmeter; H: flowmeter height; N: bolt holes quantity; L: bolt hole diameter;
K: center circle diameter of bolt hole; D: flange outside diameter.

Separated flowmeter dimensions

DN	Rated Pressure (MPa)	Outline Dimension(mm)		Flange Connection Dimension(mm)		
		A	H	D	K	n×φL
15	20K (JIS)	150	245	95	70	4×15
20		150	245	100	75	4×15
25		150	252	125	90	4×19
32		150	270	135	100	4×19
40		150	280	140	105	8×19
50		200	280	155	120	8×19
65		250	300	175	140	8×19
80		250	314	200	160	8×23
100		250	342	225	185	8×23
125		250	366	270	225	8×25
150		300	400	305	260	12×25
200		350	464	350	305	12×25
250		450	516	430	380	12×27
300		500	566	480	430	16×27

Separated flange connection dimensions

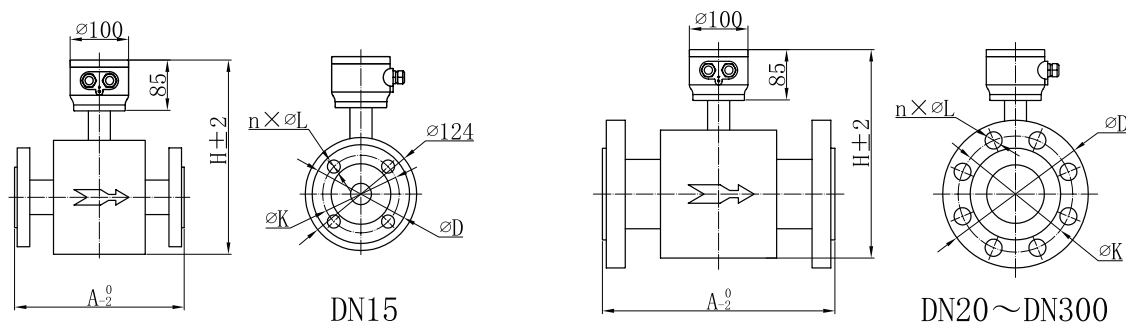

A: duct length of flowmeter; H: flowmeter height; N: bolt holes quantity; L: bolt hole diameter;
K: center circle diameter of bolt hole; D: flange outside diameter.

Separated flowmeter dimensions

DN	Rated Pressure (MPa)	Outline Dimension(mm)		Flange Connection Dimension(mm)		
		A	H	D	K	n×ΦL
15	40K (JIS)	200	245	115	80	4×19
20		200	245	120	85	4×19
25		200	247	130	95	4×19
32		200	267	140	105	4×19
40		250	275	160	120	4×23
50		250	270	165	130	8×19
65		300	295	200	160	8×23
80		300	307	210	170	8×23
100		300	337	250	205	8×23
125		300	366	300	250	8×27
150		350	398	355	295	12×33
200		400	460	405	345	12×33
250		500	514	475	410	12×33
300		500	566	540	470	16×39

Clamp type connection dimensions

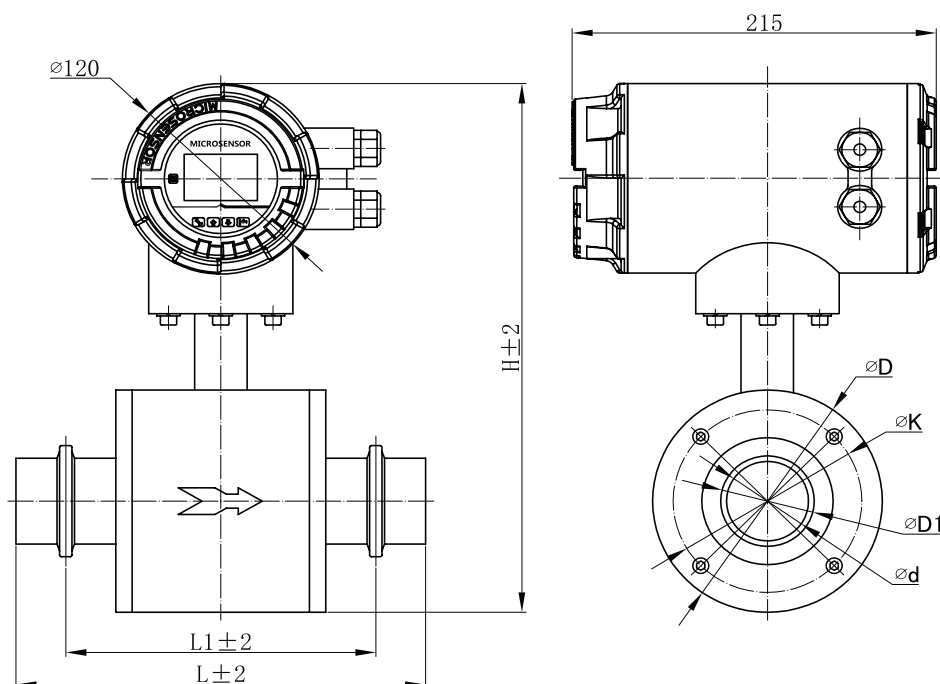

L: length of the flowmeter; L1: Clamp spacing of the flowmeter; H: Flowmeter height; D: Outer diameter; D1: Outside diameter of the flowmeter; d: Inner diameter of the flowmeter

Clamp type flowmeter dimensions

DN	Rated Pressure (MPa)	Outline Dimension(mm)			Connection Dimension(mm)		
		L	L1	H	D	D1	d
15	1.6Mpa (DIN)	250	190	296	98	19	15
20		250	190	302	104	25	21
25		250	190	304	106	32	26
32		250	190	320	122	38	32
40		300	240	322	124	45	40
50		300	240	320	122	51	47
65		300	240	340	142	76	72
80		300	240	364	166	89	85
100		300	240	388	190	108	102
125		350	290	418	220	133	127
150		350	300	446	248	159	153

05.2024 | version 0001

Wafer connection dimensions

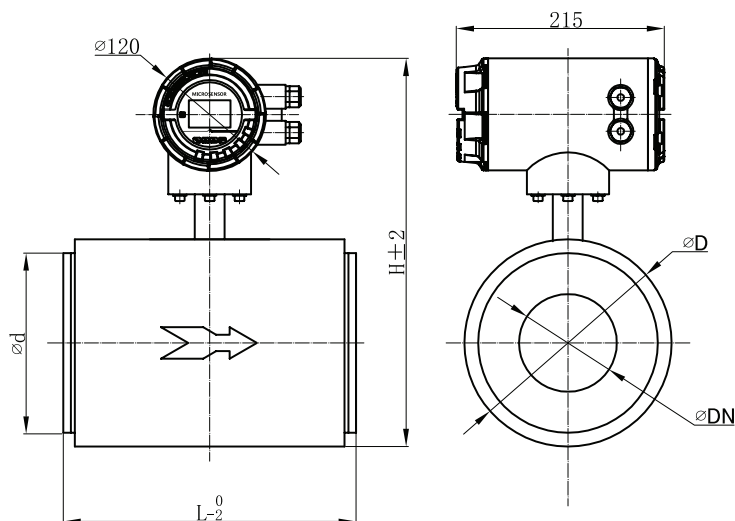

L : length of the flowmeter; H: Flowmeter height; D: Outer diameter; d: Size of the sealing surface

Wafer connection dimensions

DN	Rated Pressure (MPa)	Outline Dimension(mm)		Connection Dimension(mm)	
		L	H	D	d
25	1.6Mpa (DIN)	100	268	70	60
32		100	278	80	70
40		100	290	91	80
50		150	305	106	92
65		150	324	125	112
80		200	338	140	125
100		200	358	160	148
125		200	388	190	176
150		200	412	213	200
150		250	468	270	254
150		350	446	248	153

05.2024 | version 0001

Threaded connection dimensions

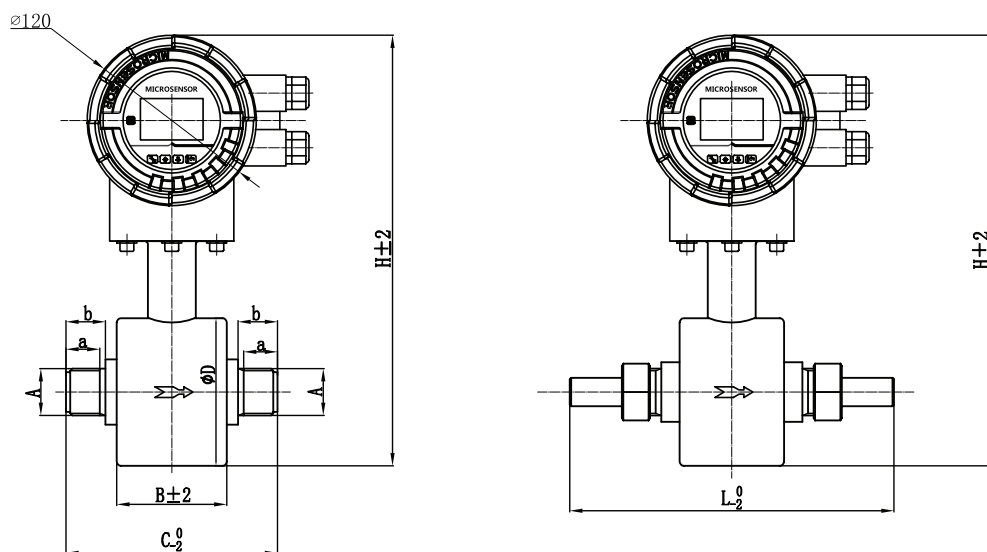

L : Duct length of flowmeter; H: Flowmeter height; D: Length of flowmeter; d: Length flowmeter body; A: Connection hole size

Threaded flowmeter dimensions

DN	Rated Pressure (MPa)	Outline Dimension(mm)		Connection Dimension(mm)		
		L	H	D	d	A
10	1.6Mpa (DIN)	220	304	155	74	ISO M27×2
15		230	304	155	78	ISO M33×2
20		200	310	142	74	ISO M42×1.5
25		200	310	140	74	ISO M42×2
32		200	316	140	74	ISO M50×2
40		250	320	164	76	ISO M60×2
50		250	314	184	100	ISO M72×2

Separated converter dimensions

The separated type is generally used in on-site maintenance and debugging reading inconvenient occasions, but also used in more severe applications, such as high-temperature fluids and vibration sources. On most occasions, the integrated and separated types can both meet the requirements. when the diameter is $\geq 500\text{mm}$, the separated type is recommended or easy maintenance; when the meter is installed below the ground, the separated type, IP68 protection level structure must be selected; when the meter is unavoidably installed at the pump outlet, please choose a separated structure meter.

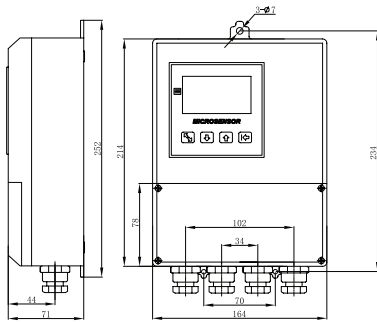

Figure 2 Separated converter dimensions

ELECTRICAL CONNECTION

The electromagnetic flowmeter converter can be divided into integrated converter and separated converter, and the wiring diagram is shown in Figure 3.

When wiring, please note:

- RS485 communication cable needs to use two-core twisted pair shielded wire;
- The same cable shall not be used for the power line and 4mA~20mA DC signal line. Two cables shall be connected separately.

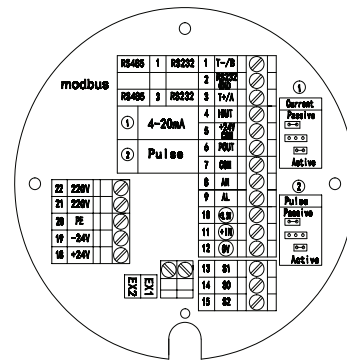

Figure 3 Integrated wiring diagram

Table 2 Terminal definition of integrated type

Terminal Symbol	Function
1	T-/B
2	RS232 GND
3	T+/A
4	IOUT
5	+24V DC COM
6	POUT
7	COM
8	AH
9	AL
10	+3.3V
11	+IN
12	0V
13	S1
14	S0
15	S2
18	+24V
19	-24V

When wiring, select the corresponding power terminal to connect to the power line according to the product specification, and then connect to the signal line according to the required output signal. See Table 4 for the specific meaning of the integrated electromagnetic flowmeter wiring terminals.

Terminal Symbol	Function
20	PE
21	220V
22	220V
	EX1
	EX2
Short Circuit lugs	Passive
	Active

05.2024 | version 0001

Separated wiring

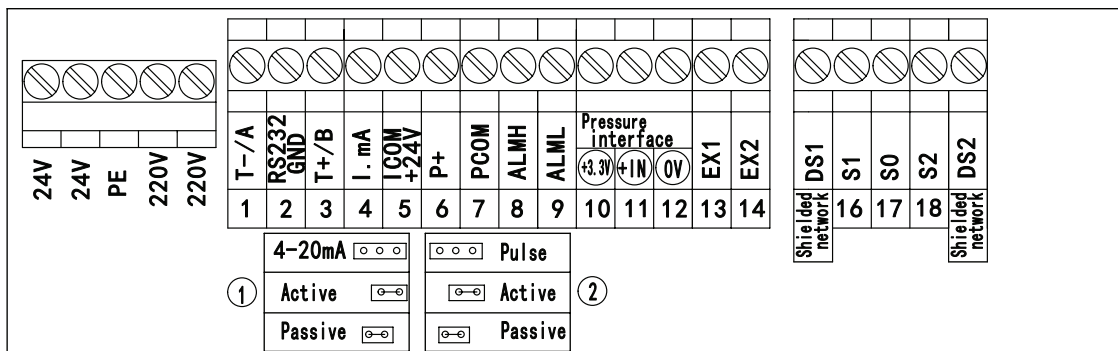

Figure 4 Separated wiring diagram

When wiring, select the corresponding power terminal to connect to the power line according to the product specifications, and then connect to the signal line according to the required output form. See Table 5 for the specific meaning of the integrated electromagnetic flowmeter wiring terminals.

Table 3 Terminal definition of separated type

Terminal Symbol	Function
1	T+/A RS485/RS232 communication output
2	RS232 GND RS232 grounding wire
3	T-/B RS485/RS232 communication input
4	I.mA 4mA~20mA DC output
5	Icom +24V Current output grounding wire
6	P+ 2-way flow pulse output/frequency output
7	Pcom Pulse output grounding wire
8	ALMH Alarm output for Upper Limit of flow
9	ALML Alarm output for Lower Limit of flow
10	+3.3V Pressure transmitter +IN
11	+IN Pressure transmitter output terminal
12	0V Pressure transmitter GND
14	EX2 Exciting current-
Shielding network	DS1
16	S1 Electrode wire
17	S0 Signal grounding wire
18	S2 Electrode wire
Shielding network	DS2
220V	220V
220V	220V
24V	24V
24V	24V
220V AC power supply access	
24V DC power supply access	
Short Circuit lugs	Passive
	Active
	When lugs are connected to Passive, the current ① or pulse ② will output an active signal.
	When lugs are connected to Active, the current ① or pulse ② will output a passive signal.

INSTALLATION

The electromagnetic flowmeter must work under the condition of full pipe, and the flowmeter cannot work normally when the pipe is not full or empty.

The correct installation method of the electromagnetic flowmeter should ensure that the pipe is filled with liquid and should not be installed high on the pipe, as shown in Figure 5.

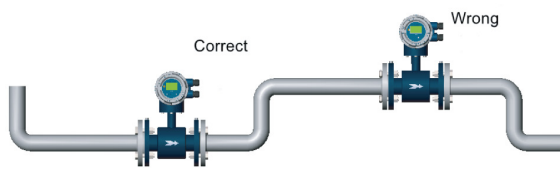

Figure 5

Front and rear straight pipe installation

In order to ensure the upstream piping conditions required for high accuracy measurement of the flowmeter, the piping installation as shown in the figure below is recommended.

When there are valves at the front and rear of the flowmeter, the front and rear straight pipe must meet the front 5D and rear 2D installation methods at least, and the valve must be fully open, as shown in Figure 6.

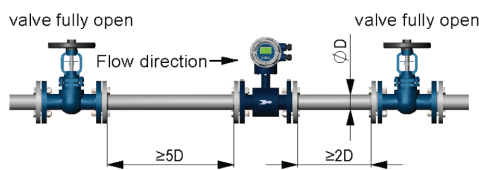

Figure 6

When flowmeter is installed at the back end of T-tube, the flowmeter and T-tube shall have a minimum of 5D straight pipe segments, as shown in Figure 7.

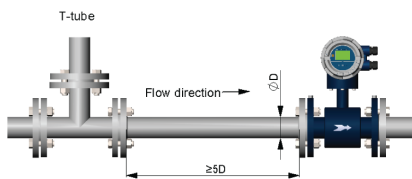

Figure 7

When the flowmeter is installed at the back end of 90°elbow pipe, at least 5D straight pipe are needed between the flowmeter and the tail end of the elbow, as shown in Figure 8.

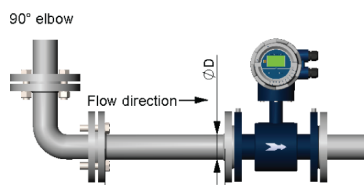

Figure 8

When the flowmeter is installed at the back end of the expanded diameter pipe, the flowmeter and the back end of the expanded diameter pipe need to ensure a minimum of 10D straight pipe, as shown in Figure 9.

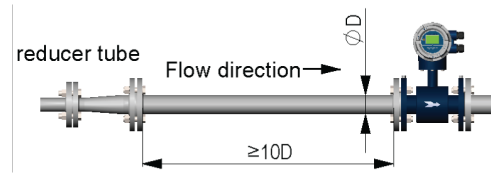

Figure 9

When the flowmeter is installed at the back end of the valve and the valve is not fully open, the flowmeter and the back end of the valve need to ensure a straight pipe section of at least 10D, as shown in Figure 10.

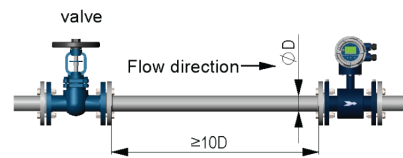

Figure 10

Installation Direction

When installing, the positive direction of liquid flow should generally be the same with the direction of the arrow on the sensor, and there must be sufficient space for installation and maintenance near the flowmeter. During installation, the flowmeter should be equipped with supports on both sides of the pipeline to prevent the flowmeter from being stressed due to pipeline vibration, impact and contraction.

When installing the flowmeter, in general, with horizontal installation, please ensure the axis of the measuring electrode is approximately horizontal; if the axis of the measuring electrode is perpendicular to the ground, bubbles can easily build up near the upper electrode which is easy to block the liquid from contacting the electrode below that is easily covered by mud or impurities. The converter is generally installed above the pipeline to prevent water from entering the converter.

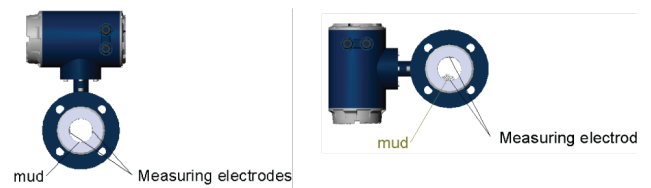

Figure 11 Flowmeter installation direction

When installing the flowmeter, please ensure the axis of the pipeline and the flowmeter measuring tube are in the same straight line. If there is an angle between the two axes, the flange connection will not be sealed well, and even the flange welding part will break.

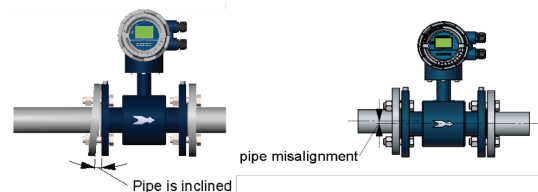

Figure 12 Flowmeter installation symmetrically with the pipe axis

SENSOR GROUNDING

Since the voltage of inductive signal of electromagnetic flowmeter is small, it is easily affected by noise. Its reference potential must be the same to the measured liquid potential. Therefore, the reference potential of the sensor (terminal potential), the reference potential of converters and amplifiers are also the same to measured liquid potential, and the liquid potential have to be the same as the ground potential. The electromagnetic flowmeter is equipped with a ground loop, which is for establishing a liquid ground via contact with liquid, and for protecting lining meanwhile.

The instrument grounding is shown as below:

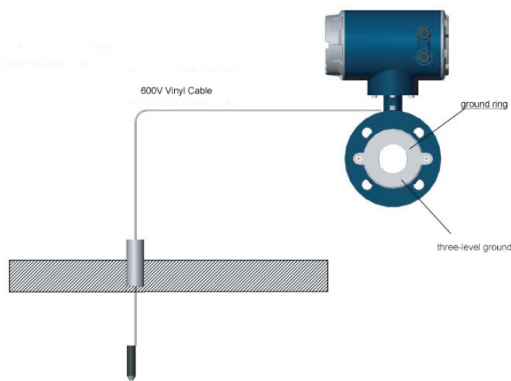

Figure 13 Instrument grounding

NOISE SUPPRESSION

Do not install Electromagnetic Flowmeter near motors, transformers or power device which is easy to cause induction interference.

ELECTROMAGNETIC FLOWMETER PRODUCT MANUFACTURING STANDARD

JB/T 9248-2015	Electromagnetic Flowmeter
JJG 1033-2007	Verification Regulations GB/T 9124.1-2019 Steel Pipe Flange
GB/T 9124.1-2019	Steel Pipe Flange
GB/T 17626.2-2018	EMC Electrostatic discharge test
GB/T 17626.3-2016	EMC Radio frequency electromagnetic field radiation
GB/T 17626.4-2008	EMC Burst disturbance
GB/T 17626.5-2019	EMC Measurement Techniques Surge (Shock) Immunity Test
GB/T 17626.8-2006	EMC Power frequency magnetic field disturbance
GB/T 4208-2017	Protection class

ORDER GUIDE

MFE600E-AS1 -100- 105 - 1.6E2 - 0001 - 0110

MFE600E	Electromagnetic Flowmeter			
AS1	Code	Sensor type		
	AS0	Standard		
	AS1	With pressure port		
	AS2	Explosion-proof CT4 (Ex d ib mb IIC T4 Gb)		
100	Code	Pipe diameter		
	xxx	For example: 100 represents DN100		
	6	DN 6	1/8"	0.05 0.71 m³/h
	10	DN 10	3/8"	0.31 4.45 m³/h
	15	DN 15	1/2"	0.56 7.92 m³/h
	20	DN 20	3/4"	0.88 12.37 m³/h
	25	DN 25	1"	1.45 20.27 m³/h
	32	DN 32	1 1/4"	2.26 31.67 m³/h
	40	DN 40	1 1/2"	3.53 49.48 m³/h
	50	DN 50	2"	5.97 83.62 m³/h
	65	DN 65	2"	9.04 126.67 m³/h
	80	DN 80	3"	14.14 197.92 m³/h
	100	DN 100	4"	22.08 309.25 m³/h
	125	DN 125	5"	31.80 445.32 m³/h
	150	DN 150	6"	56.55 791.68 m³/h
	200	DN 200	8"	88.35 1237.00 m³/h
	250	DN 250	10"	127.18 1781.28 m³/h
	300	DN 300	12"	173.18 2424.52 m³/h
	350	DN 350	14"	226.19 3166.73 m³/h
	400	DN 400	16"	286.28 4007.89 m³/h
450	DN 450	18"	353.43 4948.01 m³/h	
500	DN 500	20"	508.93 7125.13 m³/h	
600	DN 600	24"	692.72 9698.10 m³/h	
700	DN 700	28"	904.77 12666.90 m³/h	
800	DN 800	32"	1145.11 16031.54 m³/h	
900	DN 900	36"	1413.71 19792.03 m³/h	
1000	DN 1000	40"	2035.75 28500.53 m³/h	
1200	DN 1200	48"	2770.88 38792.39 m³/h	
1400	DN 1400	56"	3619.11 50667.61 m³/h	
1600	DN 1600	64"	3619.11 72382.29 m³/h	
1	Code	Electrode Type		
	1	Standard		
0	Code	Electrode Material		
	0	SS316L		
	1	Platinum (Pt)		
	2	Hastelloy BB(HB)		
	3	Tantalum (Ta)		
	4	Titanium (Ti)		
	5	HastelloyC (HC)		
6	Wolfram carbide (WC)			
5	Code	Lining material		
	1	PFA DN25-DN500 Max medium Temp. 150°C		
	2	NR DN25-DN1600 Max medium Temp. 60°C		
	3	CR DN50-DN1600 Max medium Temp. 60°C		
	4	PU DN25-DN500 Max medium Temp. 60°C		
	5	PTFE DN25-DN1600 Max medium Temp. 120°C		
	6	F46 DN6-DN600 Max medium Temp. 150°C		
9	Others			

1.6	Code	Rated pressure
	10	PN100 DIN2501, EN 1092-1 DN6-DN100
	6.3	PN63 DIN2501, EN 1092-1 DN6-DN100
	4.0	PN40 DIN2501, EN 1092-1 DN6-DN500
	2.5	PN25 DIN2501, EN 1092-1 DN6-DN500
	1.6	PN16 DIN2501, EN 1092-1 DN6-DN1600
	1.0	PN10 DIN2501, EN 1092-1 DN6-DN1600
	0.6	PN6 DIN2501, EN 1092-1 DN6-DN1600
	150LB	Class 150 ASME B16.5 DN15-DN300
	300LB	Class 300 ASME B16.5 DN15-DN300
	600LB	Class 600 ASME B16.5 DN15-DN300
	10K	JIS 10K DN15-DN300
	20K	JIS 20K DN15-DN300
	40K	JIS 40K DN15-DN300
	9	Others
	E	Code
E		≤60°C
H		≤120°C
2	Code	Ground mode
	*	Without electrode DN6-DN20
	1	With electrode
	2	304 Ground ring
	9	Others
00	Code	Converter mode
	00	Integrated IP65
	01	Integrated IP67
	10	Integrated IP68 (battery powered only)
	11	Separated IP65 (Converter IP65, Sensor IP65)
	20	Separated IP68 (Converter IP65, Sensor IP68)
	90	Others
0	Code	Analog output
	*	Without
	0	4mA-20mA
	1	4mA-20mA+Hart (Without RS485)
	9	Others
1	Code	Digital output
	0	Without
	1	RS485 MODBUS RTU
	2	Profibus-DP
	3	Wireless transmission 4G
	9	Others
0	Code	Sensor material
	0	Carbon Steel
	1	304 Stainless steel
	9	Others
1	Code	Connection mode
	1	Flange DN6-DN1600
	2	Thread DN10-DN50
	3	Wafer DN25-DN200
	4	Clamp DN15-DN150
	9	Others
1	Code	Accessories
	0	Without
	1	Carbon steel companion flange
	2	304 Stainless steel companion flange
	4	Pressure transmitter
	9	Others
0	Code	Power supply
	0	220V AC 100-240V
	1	24V DC 18V-28V
	2	12V DC
	3	Battery Power supply (With RS485)
	9	Others

05.2024 | version 0001

Notes

1. The power supply is 24V or 220V, with 4~20mA output and frequency/pulse output by default.
2. If the power supply is battery powered, the default is with RS485.
3. RS485 communication and HART communication cannot be used at the same time.
4. When the temperature is higher than 80°C, recommended to choose Separated converter.
5. DN6-DN20 without ground electrode.
6. Pressure transmitter selection: Power supply 3.3V Output 0.5V~2.5V Three-wire pressure transmitter.

Example:

MFE600E-AS1-100-105-1.6E2-0001-0110

Explanation: MFE600E Electromagnetic flowmeter; DN100 diameter; with pressure measurement interface; fixed stainless steel 316L electrodes; PTFE lining; rated pressure 1.6MPa; media temp. 0 °C ~60 °C ; ground ring; IP65 protection, integrated, with 4mADC~20mADC and RS485 digital signal; carbon steel sensor; flange connection; with companion mounting flange (including bolts and nuts), 100VAC~240VAC power supply; full range 200m³/h .

The selection of electromagnetic flowmeter should be carried out by technicians who are familiar with the on- site process conditions. The appropriate diameter, lining material, electrode, etc. should be selected according to the order guide, and determined by the end users who are familiar with the on-site process conditions.

ORDER NOTES

According to statistics from authoritative organizations in the world, one-third of the cases of flow meter failure are caused by the quality of the product itself, and two-thirds of the cases are caused by product selection and on-site installation that do not meet the requirements. The selection of electromagnetic flowmeter requires the implementation of the following parameters.

1. Collect process data
 - a. The name of the measured fluid, and the composition of the chemical substance contained;
 - b. Max. flow, min. flow, common flow;
 - c. Max. Working pressure;
 - d. Max. Temp., min. Temp.
2. The measured fluid must be conductive, conductivity > 5µS/cm.
3. The maximum flow and the minimum flow must conform to the values of the flow range in table 7.

4. When measuring cleaning media, the economic low rate is 1.5m/s~3m/s; When measuring easy crystallization solution, the flow rate should be appropriately increased to 3m/s~4m/s to automatically clean and prevent adhesion deposition; for measuring ore slurry, etc. For wear-resistant fluids, the flow rate should be appropriately reduced to 1m/s~2m/s to reduce the wear on the lining and electrodes. In practical applications, there is rarely a flow velocity exceeding 7m/s, and it is even rarer to exceed 10m/s.
- 5) The actual maximum working pressure must be less than the rated working pressure of the flowmeter.
- 6) The maximum and minimum working temperature must meet the requirements specified in the flowmeter.
- 7) Confirm whether there is negative pressure in process pipeline.

ATTENTIONS

1) Measurement accuracy

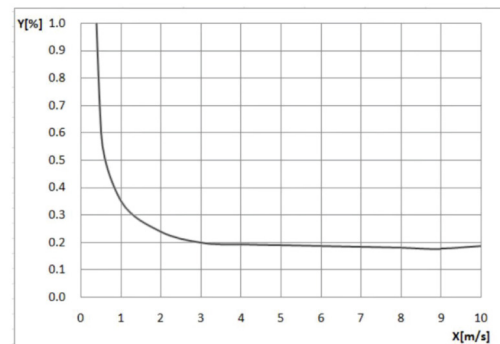

X[m / s]: flow rate

Y[m / s]: Deviation of actual measurement

DN6-DN1600 0.5% of measured value + 1 mm/s

2) Flow range

Table 4 Flow range

Flow m ³ /h							
DN mm	Velocity m/s						
	0.5	1	2	3	4	5	7
6	0.0509	0.1018	0.2036	0.3054	0.4072	0.5089	0.7125
10	0.1414	0.2827	0.5655	0.8482	1.1310	1.4137	1.9792
15	0.3181	0.6362	1.2723	1.9085	2.5447	3.1809	4.4532
20	0.5655	1.1310	2.2619	3.3929	4.5239	5.6549	7.9168
25	0.8836	1.7671	3.5343	5.3014	7.0686	8.8357	12.3700
32	1.4476	2.8953	5.7906	8.6859	11.5812	14.4765	20.2670
40	2.2619	4.5239	9.0478	13.5717	18.0956	22.6195	31.6673
50	3.5343	7.0686	14.1372	21.2058	28.2743	35.3429	49.4800
65	5.9730	11.9459	23.8918	35.8377	47.7836	59.7295	83.6213
80	9.0478	18.0956	36.1911	54.2867	72.3823	90.4779	126.6690
100	14.1372	28.2743	56.5487	84.8230	113.0973	141.3717	197.9203
125	22.0893	44.1786	88.3573	132.5359	176.7146	220.8932	309.2505
150	31.8086	63.6173	127.2345	190.8518	254.4690	318.0863	445.3208
200	56.5487	113.0973	226.1947	339.2920	452.3893	565.4867	791.6813
250	88.3573	176.7146	353.4292	530.1438	706.8583	883.5729	1237.0021
300	127.2345	254.4690	508.9380	763.4070	1017.8760	1272.3450	1781.2830
350	173.1803	346.3606	692.7212	1039.0818	1385.4424	1731.8030	2424.5241
400	226.1947	452.3893	904.7787	1357.1680	1809.5574	2261.9467	3166.7253
450	286.2776	572.5553	1145.1105	1717.6658	2290.2210	2862.7763	4007.8868
500	353.4292	706.8583	1413.7167	2120.5750	2827.4334	3534.2917	4948.0083
600	508.9380	1017.8760	2035.7520	3053.6281	4071.5041	5089.3801	7125.1320
700	692.7212	1385.4424	2770.8847	4156.3271	5541.7694	6927.2118	9698.0964
800	904.7787	1809.5574	3619.1147	5428.6721	7238.2295	9047.7868	12666.9014
900	1145.1105	2290.2210	4580.4421	6870.6631	9160.8842	11451.1052	16031.5470
1000	1413.7167	2827.4334	5654.8668	8482.3002	11309.7336	14137.1669	19792.0334
1200	2035.7520	4071.5041	8143.0082	12214.512	16286.0163	20357.5204	28500.5281
1400	2770.8847	5541.7694	11083.538	16625.308	22167.0778	27708.8472	38792.3854
1600	3619.1147	7238.2295	14476.458	21714.459	28952.9179	36191.1474	50667.6055

05.2024 | version 0001

3) Electrode material

Table 5 Electrode material property

Material	Corrosion resistance	Applicability
316L	Domestic water, industrial water, raw water, groundwater, urban sewage, treated neutral industrial sewage	<input checked="" type="checkbox"/>
	Acid, alkali, salt	<input type="checkbox"/>
Hastelloy B (HB)	Weak organic acid	<input checked="" type="checkbox"/>
	Reducing acids such as nitric acid, hydrochloric acid, phosphoric acid, and hydrofluoric acid	<input type="checkbox"/>
Hastelloy C (HC)	Oxidizing salts such as Fe ³⁺ , sea water	<input checked="" type="checkbox"/>
	Reducing acids such as nitric acid, hydrochloric acid, phosphoric acid, and hydrofluoric acid	<input type="checkbox"/>
Titanium (Ti)	Chloride (chloride/magnesium/aluminum/calcium/ammonium/iron, etc.)	<input checked="" type="checkbox"/>
	Ammonia, sodium salt, potassium salt, ammonium salt, hypochlorite, sea water	
	Sodium hydroxide, potassium hydroxide, ammonium hydroxide, barium hydroxide and other alkaline solutions with a concentration of less than 50%	
	Nitric acid, hydrochloric acid, sulfuric acid, phosphoric acid, hydrofluoric acid and other reducing acids	<input type="checkbox"/>
Tantalum (Ta)	Hydrochloric acid (concentration less than 40%), dilute sulfuric acid and concentrated sulfuric acid	<input checked="" type="checkbox"/>
	Chlorine dioxide, ferric chloride, hypochlorous acid, sodium cyanide, lead acetate, etc.	
	Oxidizing acid such as nitric acid, aqua regia with temperature lower than 80°C	
	Alkali, hydrofluoric acid	<input type="checkbox"/>
Platinum (Pt)	Almost all acid, alkali, salt solutions	<input checked="" type="checkbox"/>
	Aqua regia, ammonium salt	<input type="checkbox"/>
Wolfram carbide (WC)	Treated neutral industrial sewage, domestic sewage, can resist the interference of solid particles	<input checked="" type="checkbox"/>
	Acid, alkali, salt	<input type="checkbox"/>

4) Lining material

Table 6 Lining material property

Lining Material	Symbol	Property	Working temp.	Applicable liquid	Applicable diameter
Neoprene	CR	Medium abrasion resistance, resistant to corrosion by low-concentration alkali and salt	-10°C ~ 60°C	Tap water, domestic sewage	DN50 ~ DN1600
Natural rubber	NR		-10°C ~ 60°C		
Polyurethane rubber	PU	Excellent abrasion resistance, poor acid and alkali resistance	-10°C ~ 60°C	Pulp, mineral pulp and other slurries	DN25 ~ DN600
Polytetrafluoro ethylene	F4 (PTFE)	The chemical performance is very stable, resistant to the corrosion of boiling hydrochloric acid, sulfuric acid, aqua regia and concentrated alkali	-20°C ~ 120°C	Corrosive acid, alkali, salt liquid	DN25 ~ DN1600
Polyperfluoro ethylene propylene	F46 (FEP)	The chemical performance is equivalent to F4, and the compressive and tensile strength is better than F4	-20°C ~ 150°C	Corrosive acid, alkali, salt liquid	DN6 ~ DN500
Copolymer of tetrafluoroethylene and perfluorinated hydrocarbon vinyl ether	PFA	The chemical properties are equivalent to F46, and the compressive and tensile strength is better than F4	-20°C ~ 150°C	Corrosive acid, alkali, salt liquid	DN6 ~ DN500