



bar **MPM280**

FEATURES

- Pressure range: 0bar ~ 1.0bar...700bar
- Gauge, Absolute and Sealed gauge
- Constant current or Constant voltage power supply for option
- Isolated construction to measure various fluid media
- Φ 19mm OEM pressure element
- Different metals with excellent corrosion resistance for option
- negative pressure measurement is available, the lowest to around -1bar

APPLICATION

- Industrial process control
- Level measurement
- Gas, Liquid pressure measurement
- Pressure meter
- Pressure calibrator
- Liquid pressure system and switch
- Refrigeration equipment and Air conditioner
- Aviation and Navigation inspection

ELECTRICAL PERFORMANCE

| | |
|----------------------------|---|
| Power supply | $\leq 2.0\text{mA DC}$ |
| Electrical connection | $\varnothing 0.5\text{mm}$ Kovar pin or 100mm silicon rubber flexible wires |
| Common mode voltage output | 50% of input (typ.) |
| Input impedance | 3k Ω ~8k Ω |
| Output impedance | 3.5k Ω ~6k Ω |
| Response (10%~90%) | <1ms |
| Insulation resistor | 100M Ω @100V DC |
| Overpressure | 2 times FS or 1100bar(min. value is valid) |

ENVIRONMENTAL CONDITIONS

| | |
|---------------------|---|
| Shock | No change at 10gRMS,(20~2000)Hz |
| Impact | 100g, 11ms |
| Media compatibility | Liquid or gas that is compatible with construction material and FKM |



MICROSENSOR
AUTHORIZED DISTRIBUTOR

MPM280TH pressure sensor has similar outline, installation dimension and sealing methods as general MPM280 pressure sensor. For construction material, the isolated diagram uses tantalum material and housing uses Hastelloy C material. The sensor is sealed by FKM O-ring. It can be used to measure strongly corrosive media. The pressure range is -1.0bar~0bar~1.0bar...350bar.

MPM280TS pressure sensor has similar outline, installation dimension and sealing methods as general MPM280 pressure sensor. For construction material, the isolated diagram uses tantalum material and housing uses stainless steel 316L material. The sensor is sealed by FKM O-ring. It can be used to measure strongly corrosive media. The pressure range is -1.0bar~0bar~1.0bar...350bar.

MPM280HH pressure sensor has similar outline, installation dimension and sealing methods as general MPM280 pressure sensor. It uses all Hastelloy C material in construction, The sensor is sealed by FKM O-ring. It can be used to measure strongly corrosive media. The pressure range is -1.0bar~0bar~1bar...350bar.

MPM280Ti pressure sensor has similar outline, installation dimension and sealing methods as general MPM280 pressure sensor. It uses all titanium material in construction, TC4 housing material and TA1 diaphragm. It can be used to measure sea water or corrosive media. The pressure range is 1.0bar~0bar~1.0bar...700bar.

MPM 280Ti Pressure Sensor can be used in wet environment or sea water. Its anti-corrosive performance is far better than stainless steel. MPM280Ti has good anti-corrosive performance for pitting, acid etching, stress corrosion, alkali, chloride, chlorine-organism, nitric acid and vitriol etc.

CONSTRUCTION PERFORMANCE

| | |
|-----------------------|---|
| Diaphragm | Titanium (MPM280Ti) Tantalum (MPM280TH, MPM280TS) Hastelloy C(MPM280HH) |
| Housing | Titanium (MPM280Ti) Hastelloy C(MPM280TH, MPM280HH) |
| Pressure leading tube | Stainless steel 316L |
| Pin | Kovar |
| O-ring | FKM |
| Net weight | ~23g(general type, MPM280TH, MPM280TS and MPM280HH) ~13.5g (MPM 280Ti) |

BASIC CONDITIONS

| | |
|-------------------------|--------------------------------|
| Media temperature | (25±1)°C |
| Environment temperature | (25±1)°C |
| Shock | 0.1g (1m/s ²) Max. |
| Humidity | (50±10)%RH |
| Local air pressure | (0.86 ~ 1.06)bar |
| Power supply | (1.5±0.0015)mA DC |

SPECIFICATION

| Item* | Min. | Typ. | Max. | Units |
|-------------------------|------|---------|--------|------------|
| Linearity | | ±0.15 | ±0.25 | %FS,BFSL |
| Repeatability | | ±0.05 | ±0.075 | %FS |
| Hysteresis | | ±0.05 | ±0.075 | %FS |
| Zero output | | ±1.0 | ±2.0 | mV DC |
| Output/Span** | 70 | | | mV DC |
| Zero thermal error | | ±0.75 | ±1.0 | %FS, @25°C |
| FS thermal error | | ±0.75 | ±1.0 | %FS, @25°C |
| Compensated temp. range | | 0~50 | | °C |
| Working temp. range | | -40~125 | | °C |
| Storage temp. range | | -40~125 | | °C |
| Long-term stability | | ±0.2 | ±0.3 | %FS/Year |

*Testing at basic condition,G: Gauge; A: Absolute; S: Sealed gauge

** Output/Span=full scale output - zero point

0.7bar A, 1.0bar A, 0.7bar GY, 1.0bar GY, FS output ≥45mV
2.0bar A, 3.5bar A, 2.0bar GY, 3.5bar GY, FS output ≥60mV

OUTLINE CONSTRUCTION (UNIT:mm)

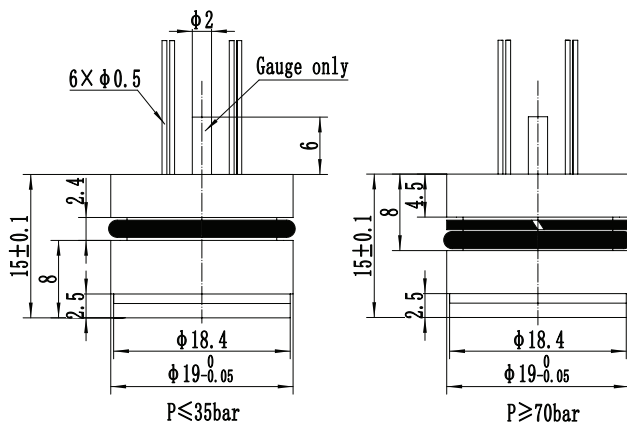

ELECTRICAL CONNECTION

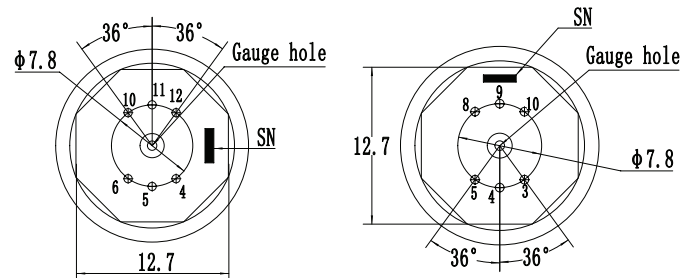

For option 0 or null, suggested installation dimension is
Φ19^{+0.05}_{+0.02} mm

| Pin | Definition | Wire color |
|------------------------|------------|-----------------|
| 4 | +OUT | Red |
| 5 | +IN | Black |
| 6 | -IN | Yellow or White |
| 10 | -OUT | Blue |
| Other pins are useless | | |

| Pin | Definition | Wire color |
|------------------------|------------|-----------------|
| 4 | +OUT | Red |
| 5 | -IN | Yellow or White |
| 8 | +IN | Black |
| 9 | -OUT | Blue |
| Other pins are useless | | |

| Pin | Definition | Wire color |
|------------------------|------------|-----------------|
| 4 | -OUT | Blue |
| 5 | -IN | Yellow or White |
| 8 | +IN | Black |
| 9 | +OUT | Red |
| Other pins are useless | | |

Notes

- The actual electrical connection method, please check the parameter label enclosed with products.

ORDER GUIDE

| MPM280 | | Anti-corrosive Pressure Sensor | | | | |
|--|------|--------------------------------|---|------------|-------------|-------|
| MPM280TH | code | range | Ref. | Range code | range | Ref. |
| MPM280TS | 02 | 0bar~0.7bar | G.A | 13 | 0bar~35bar | G.S.A |
| MPM280HH | 03 | 0bar~1bar | G.A | 14 | 0bar~70bar | S.A |
| MPM280Ti | 07 | 0bar~2bar | G.A | 15 | 0bar~100bar | S.A |
| | 08 | 0bar~3.5bar | G.A | 17 | 0bar~200bar | S.A |
| | 09 | 0bar~7bar | G.A | 18 | 0bar~350bar | S.A |
| | 10 | 0bar~10bar | G.A | 19 | 0bar~700bar | S.A |
| | 12 | 0bar~20bar | G.A | | | |
| | | Code | Pressure type | | | |
| | | G | Gauge | | | |
| | | A | Absolute | | | |
| | | S | Sealed gauge | | | |
| | | Code | Pressure connection | | | |
| | | 0 or null | O-ring | | | |
| | | Code | Compensation | | | |
| | | L | Laser trimming | | | |
| | | M | Outer compensated resistor (providing resistor value) | | | |
| | | Code | Electrical connection | | | |
| | | 1 | Kovar pin(default) | | | |
| | | 2* | 100mm silicon rubber flexible wires | | | |
| | | Code | Special measurement | | | |
| | | Y | Gauge sensor to measure vacuum (-1bar ~ 0bar) | | | |
| MPM280HH | 09 | G | 0 | L | 1 | Y |
| the whole spec | | | | | | |
| *The default code for electrical connection is "1" on the parameter card. And it is also allowed to print code "1" if the electrical connection is flexible wire (original code "2"). The wire length shall be as per customers' request on the contact. | | | | | | |

Notes:

- The default unit of the company's products is kPa, 1kPa=0.01bar.
- It is recommended that the sensor should be installed as Suspended Mode to avoid face tight press and avoid affecting sensor stability.
- Please pay attention to protect the diaphragm and the compensated board to prevent any damage or bad performance.
- Temperature resistant range of standard FKM O-ring of sensor is -20 °C ~250 °C . When working temperature is lower than -20 °C , or sensor is applied in critical environment, please contact us.

The information provided herein is to the best of our knowledge true and accurate, it is provided for guidance only. All specifications are subject to change without prior notification.

Althen is the innovative sensor expert that creates integrated sensor and measurement solutions for the creators of tomorrow | althensensors.com

We create integrated sensor and measurement solutions. In addition we offer services such as calibration, repairs, design & engineering, training and renting of measurement equipment.

Benelux
sales@althen.nl

Germany/Austria/Switzerland
info@althen.de

France
info@althensensors.fr

Sweden
info@althensensors.se

USA/Canada
info@althensensors.com

Other countries
info@althensensors.com